

**NICHIA CORPORATION**

## **SPECIFICATIONS FOR ILLUMINANT A STANDARD LED**

### **NLSL60S01A**

- LED reference standard with temperature control unit for illuminance calibration

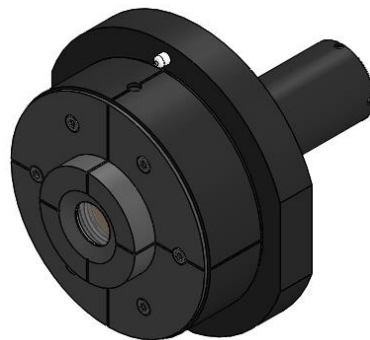

## SPECIFICATIONS

### (1) Absolute Maximum Ratings

Item	Symbol	Absolute Maximum Rating	Unit
Forward Current	$I_F$	300	mA
Allowable Reverse Current	$I_R$	85	mA
Operating Temperature	$T_{opr}$	20~30	°C
Storage Temperature	$T_{stg}$	-30~85	°C
Platinum Resistance Temperature Device (RTD) Current	$I_{pt}$	2	mA
Peltier Device Current	$I_{pel}$	-2~2	A
Peltier Device Voltage	$V_{pel}$	-15~15	V

\* Absolute maximum ratings at  $T_A=25^\circ\text{C}$ .

\* RTD uses Pt100 class A (JIS C 1604-1997).

### (2) Initial Electrical/Optical Characteristics

Item	Symbol	Condition	Typ	Unit
Forward Voltage	$V_F$	$T_{pt}=90^\circ\text{C}$ , $I_F=300\text{mA}$	32.8	V
Illuminance	$E_v$	$T_{pt}=90^\circ\text{C}$ , $I_F=300\text{mA}$	185	lx

\* Characteristics at  $T_A=25^\circ\text{C}$ .

\* The typical value of illuminance is traceable to the national standards.

\* Illuminance at 1m of photometric distance.

\* Platinum RTD temperature ( $T_{pt}$ ) must be controlled between  $85^\circ\text{C}$  and  $95^\circ\text{C}$ .

\* The LED incorporated into the socket was characterized.

\* The product seasoned for 200 hours at  $T_A=25^\circ\text{C}$ ,  $I_F=300\text{mA}$  was characterized.

\* The stability of the characteristics during use varies depending on the directions for use.

### (3) Illuminance Maintenance

Guaranteed maximum fluctuation of illuminance is  $\pm 2\%$  of the initial value.

\* The period of a shorter time between 100 hours at operation and 1 year.

\* The continuous operation at  $T_A=25^\circ\text{C}$ ,  $T_{pt}=90^\circ\text{C}(\pm 0.03^\circ\text{C})$ , and  $I_F=300\text{mA}(\pm 0.1\%)$ .

## DIRECTIONS FOR USE

### (1) Auxiliary Equipment and System Requirements

- The following figure shows how this product is connected.

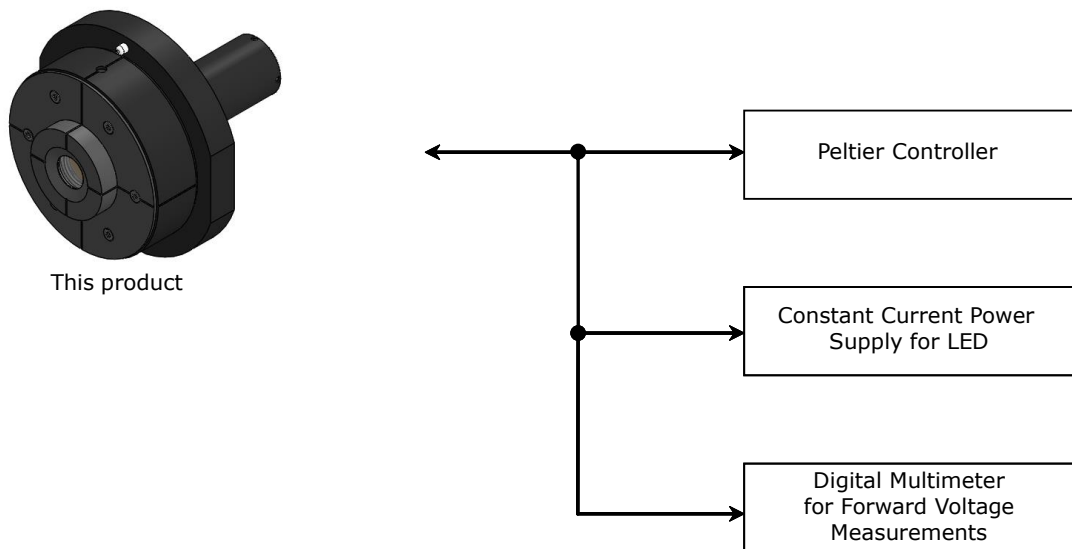

Recommended specifications for the peripheral equipment

Peltier Controller	PID Controller Temperature measurement accuracy of $\pm 0.03^{\circ}\text{C}$ .
Constant Current Power Supply for LED	Drive current accuracy: $\leq 0.1\%$ of the set current
Digital Multimeter for Forward Voltage Measurements	Input impedance: $\geq 1\ \text{G}\Omega$

### (2) Installation

- The following figure shows how the product should be held by a holder.

Example 1:

Example 2:

(Held by the part with 62mm diameter)

(Held by the part with 20mm diameter)

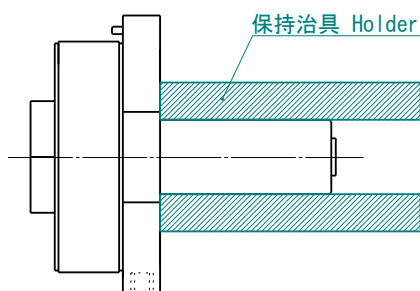
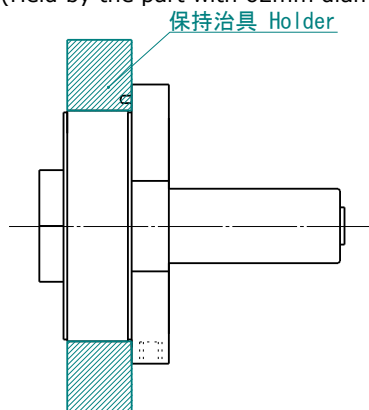

### (3) Measurement

- The product should be measured when illuminance has stabilized after the start of temperature control and constant current drive. Typically, this product will be stable and ready to be used for calibration within 15 minutes. Please refer to "LIGHT-UP TIME CHARACTERISTICS" on the following page for the characteristics during the first 30 minutes after the LED starts emission.

# OUTLINE DIMENSIONS

NLSL60S01A

管理番号 No. SQST-DA6-0001

\* 括弧で囲まれた寸法は参考値です。

The dimension(s) in parentheses are for reference purposes.

(単位 Unit:mm)

(公差 Tolerance: ±0.2(≤30), ±0.3(≤120))

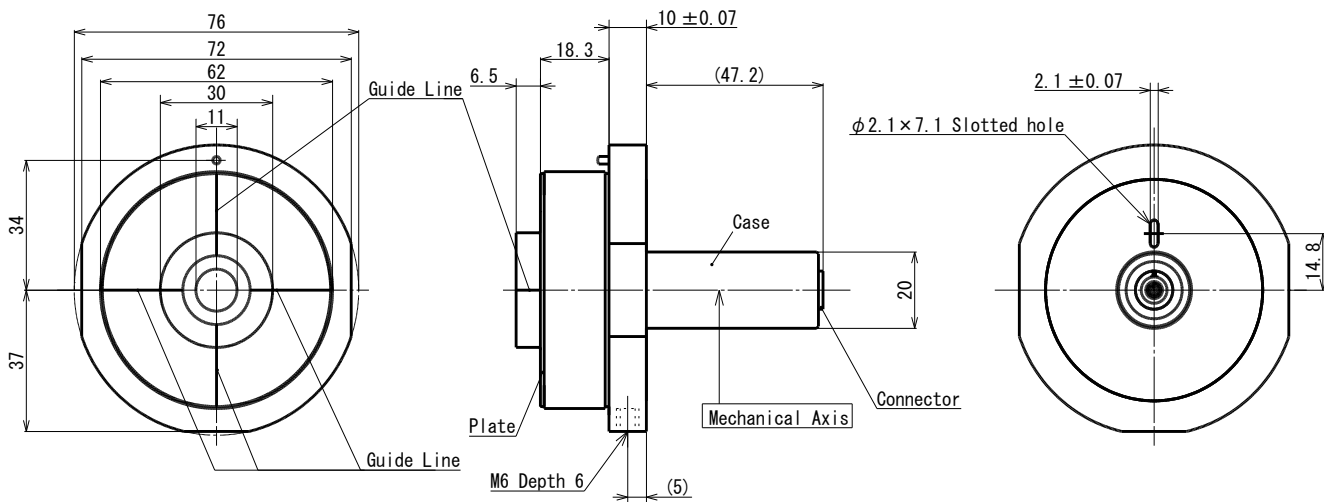

項目 Item	内容 Description	数量 Quantity
コネクタ Connector	Part No.:EGJ.0B.309.CLA (from LEMO JAPAN Ltd.)	1
ケース Case	材質:アルミニウム Material:Aluminum	1
プレート Plate	材質:アルミニウム Material:Aluminum	1

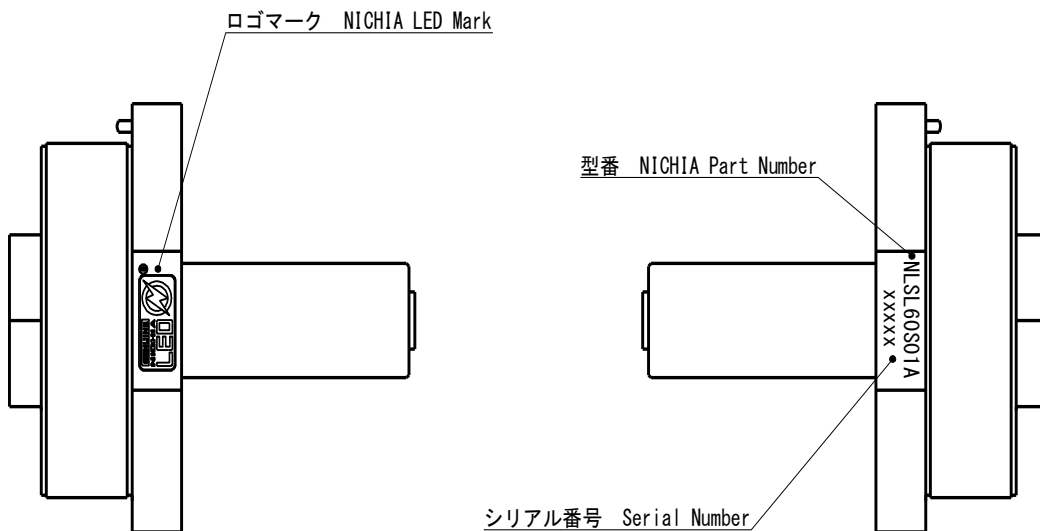

WIRING CONNECTION

NLSL60S01A

管理番号 No. SQST-DA6-0002

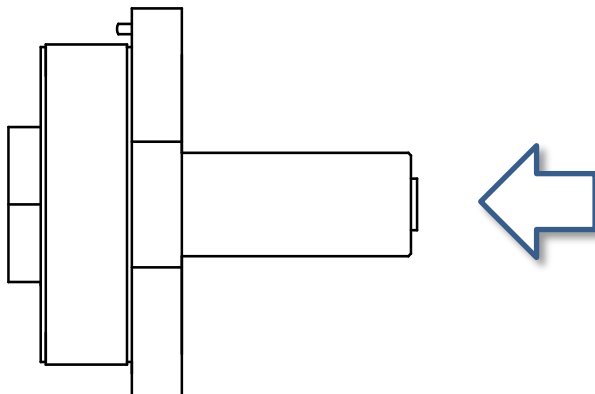

矢印方向から見たコネクタ図は以下を参照してください  
 Refer to the following illustration for the connector pin numbering  
 (viewed from direction of the arrow).

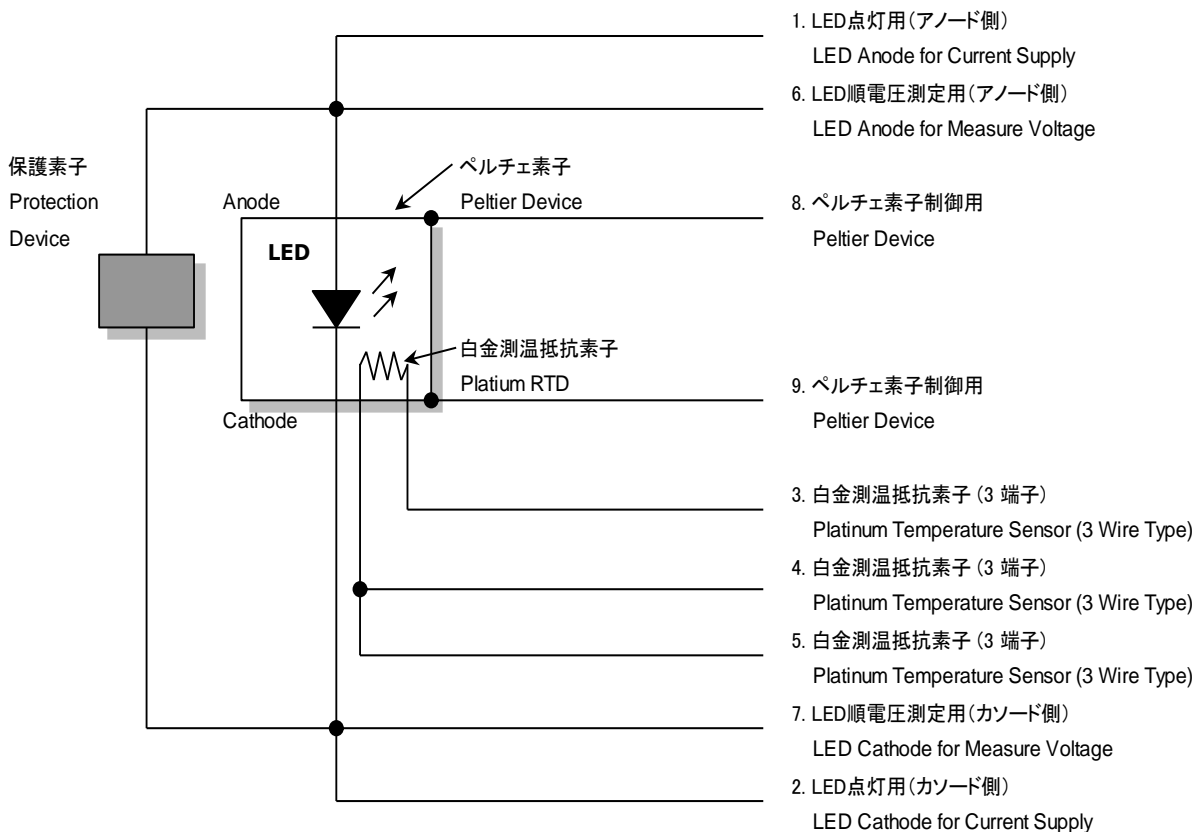
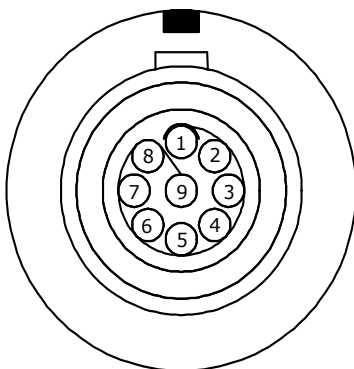

## PACKAGING

NLSL60S01A

管理番号 No. SQST-DA6-0003



\* 製品、キャップ、シリカゲルをアルミ防湿袋に入れ、熱シールにより封をします。

Place products, caps and desiccant (silica gel) case into a moisture proof foil bag with desiccant (silica gel) and then heat seal it.

\* 製品を入れたアルミ防湿袋をプラスチックケースに入れます。

Place the bag in a plastic case.

\* プラスチックケースを梱包材と共に段ボール箱に入れます。

Place a plastic case in a cardboard box with packing materials.

\* 段ボール箱のふたをガムテープで止めます。

Seal the box with packing tape.

\* プラスチックケースには出荷先、型名、数量、備考を明記したラベルを貼りつけます。

Attach a label identifying "User Name, Part No., Quantity, Notes" to the plastic case.

# OPTICAL CHARACTERISTICS

\* 本特性は参考です。  
All characteristics shown are for reference only and are not guaranteed.

NLSL60S01A  
管理番号 No. SQST-DA6-0004

## 発光スペクトル Spectrum

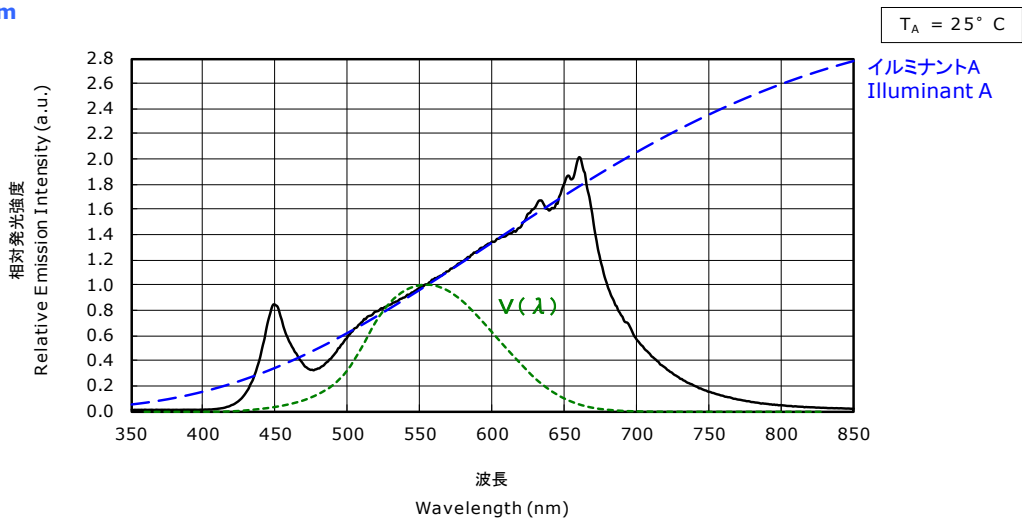

## 指向特性 Directivity

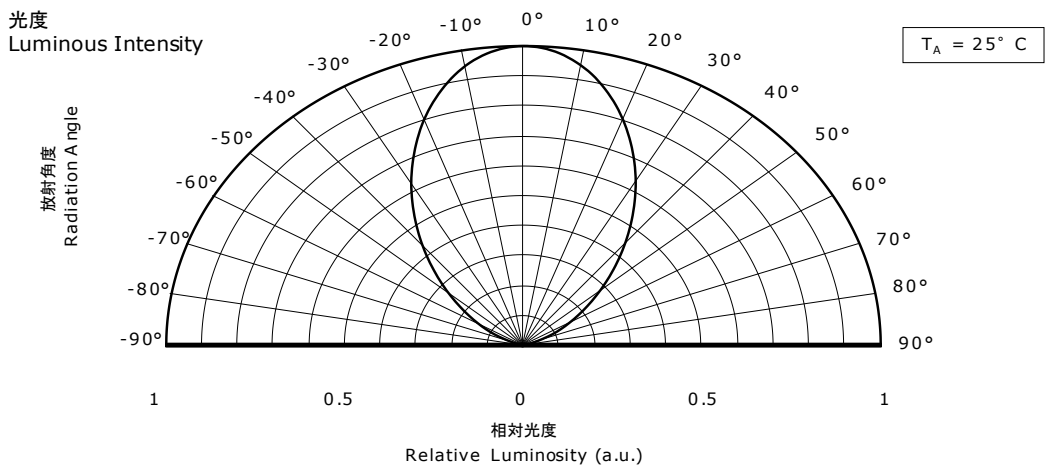

## 相関色温度 Correlated Colour Temperature

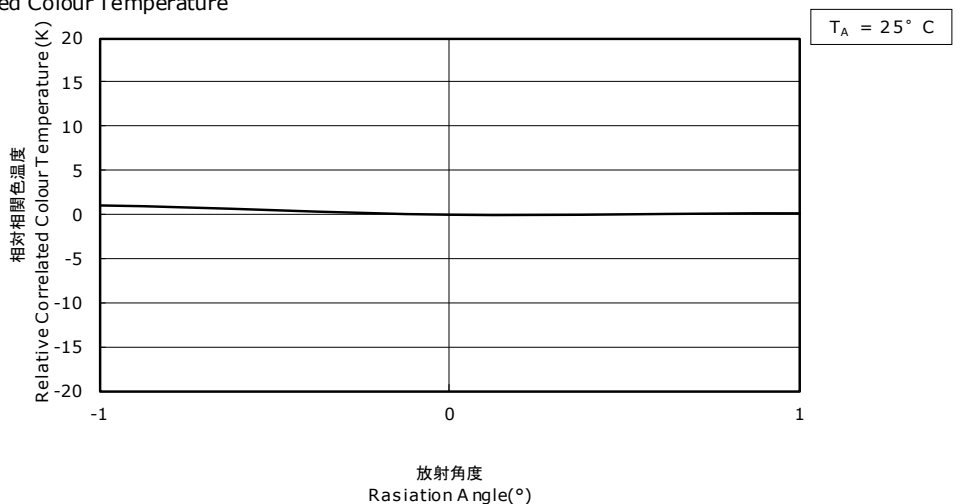

\* 標準LEDに取り付けられた白金測温抵抗素子の温度が90°Cになるように温度コントロールしたときの特性です (I<sub>F</sub> = 300 mA)。

The graphs show the characteristics when the platinum RTD incorporated in the Standard LED is controlled to be 90°C.

\* 温度コントローラーの温度制御安定度は±0.03°Cです(メーカー仕様値)。

Stability of temperature controller is ±0.03°C. (Manufacturer specification value)

# LIGHT-UP TIME CHARACTERISTICS / ILLUMINANCE TEMPERATURE CHARACTERISTICS

\* 本特性は参考です。  
All characteristics shown are for reference only and are not guaranteed.

NLSL60S01A  
管理番号 No. SQST-DA6-0005

点灯時間 - 相対順電圧特性  
Time vs  
Relative Forward Voltage

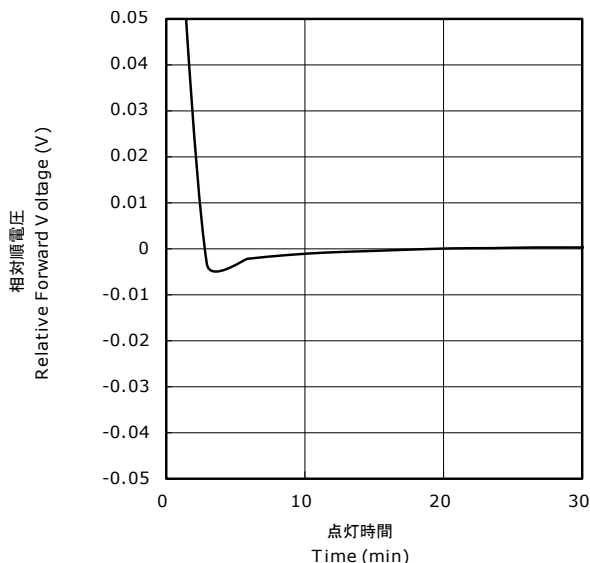

点灯時間 - 相対照度  
Time vs  
Relative Illuminance

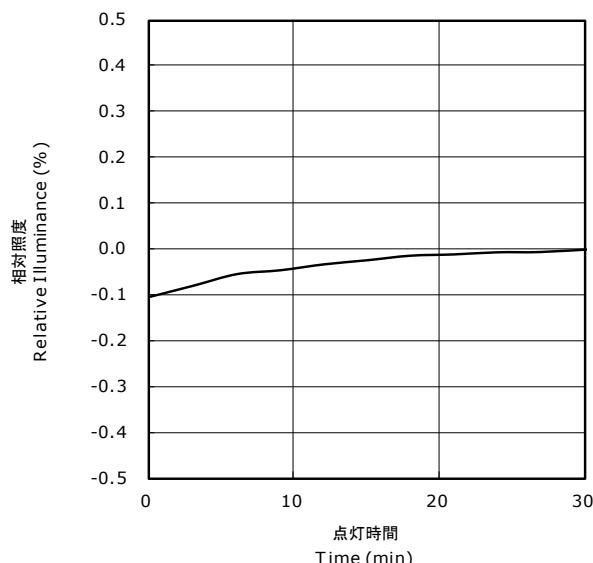

点灯時間 - 相対相関色温度特性  
Time vs  
Relative Correlated Colour Temperature

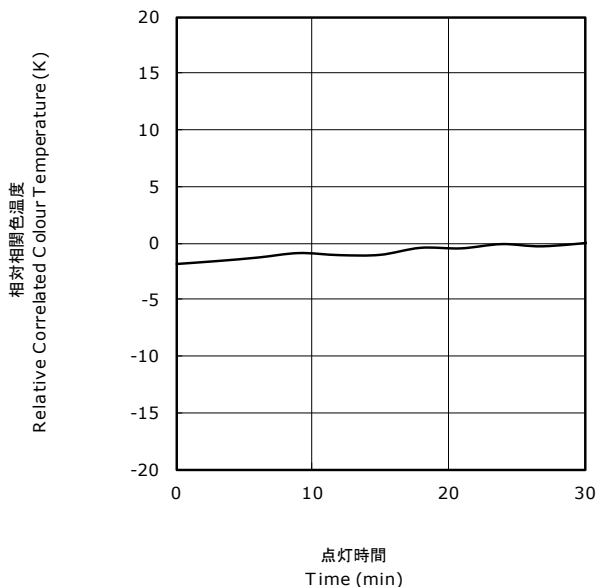

周囲温度 - 相対照度  
Ambient Temperature vs  
Relative Illuminance

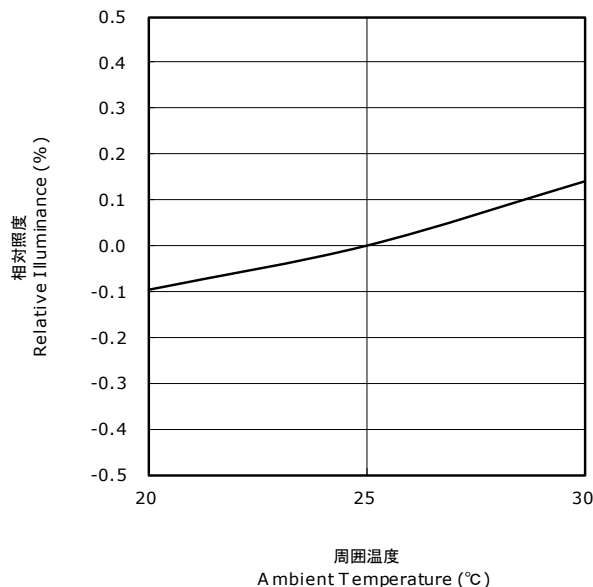

\* 標準LEDに取り付けられた白金測温抵抗素子の温度が90 °Cになるように温度コントロールしたときの特性です ( $I_F = 300 \text{ mA}$ )。

The graphs show the characteristics when the platinum RTD incorporated in the Standard LED is controlled to be 90 °C.

\* 温度コントローラーの温度制御安定度は $\pm 0.03 \text{ }^\circ\text{C}$ です(メーカー仕様値)。

Stability of temperature controller is  $\pm 0.03 \text{ }^\circ\text{C}$ . (Manufacturer specification value)

\* 点灯時間-相対順電圧特性、点灯時間-相対照度特性、点灯時間-相対相関色温度特性、周囲温度-相対照度特性は、 $T_A = 25 \text{ }^\circ\text{C}$ 、LED点灯30 min後の値を基準としています。

The graphs show the data relative to the point (after an operation time of 30 min at  $T_A = 25 \text{ }^\circ\text{C}$ ).



## CAUTIONS

### (1) Storage

- The products should be stored in an air tight container with desiccant (silica gel) at 30°C or less and 70% RH or less.
- To avoid condensation, the products must not be stored in the areas where temperature and humidity fluctuate greatly.

### (2) Handling Precautions

- Do not expose the product to shock or touch the diffused plate. Failure to comply might affect on its characteristics.

### (3) Design Consideration

- Volatile organic compounds that have been released from materials present around the LEDs (e.g. housing, gasket/seal, adhesive, secondary lens, lens cover, etc.) may penetrate the LED lens and/or encapsulating resin. If the LEDs are being used in a hermetically sealed environment, these volatile compounds can discolor after being exposed to heat and/or photon energy and it may greatly reduce the LED light output and/or color shift. In this case, ventilating the environment may improve the reduction in light output and/or color shift. Perform a light-up test of the chosen application for optical evaluation to ensure that there are no issues, especially if the LEDs are planned to be used in a hermetically sealed environment.

### (4) Electrostatic Discharge (ESD)

- This LED is sensitive to transient excessive voltages (e.g. ESD, lightning surge). If this excessive voltage occurs in the circuit, it may cause the LED to be damaged causing issues (e.g. the LED to become dimmer or not to illuminate [i.e. catastrophic failure]). Ensure that when handling the LEDs, necessary measures are taken to protect them from an ESD discharge. The following examples are recommended measures to eliminate the charge:
  - Grounded wrist strap, ESD footwear, clothes, and floors
  - Grounded workstation equipment and tools
  - ESD table/shelf mat made of conductive materials

### (5) Eye Safety

- There may be two important international specifications that should be noted for safe use of the LEDs: IEC 62471:2006 Photobiological safety of lamps and lamp systems and IEC 60825-1:2001 (i.e. Edition 1.2) Safety of Laser Products - Part 1: Equipment Classification and Requirements. Ensure that when using the LEDs, there are no issues with the following points:
  - LEDs have been removed from the scope of IEC 60825-1 since IEC 60825-1:2007 (i.e. Edition 2.0) was published. However, depending on the country/region, there are cases where the requirements of the IEC 60825-1:2001 specifications or equivalent must be adhered to.
  - LEDs have been included in the scope of IEC 62471:2006 since the release of the specification in 2006.
  - Most Nichia LEDs will be classified as the Exempt Group or Risk Group 1 according to IEC 62471:2006. However, in the case of high-power LEDs containing blue wavelengths in the emission spectrum, there are LEDs that will be classified as Risk Group 2 depending on the characteristics (e.g. radiation flux, emission spectrum, directivity, etc.)
  - If the LED is used in a manner that produces an increased output or with an optic to collimate the light from the LED, it may cause damage to the human eye.
- If an LED is operated in a manner that emits a flashing light, it may cause health issues (e.g. visual stimuli causing eye discomfort). The system should be designed to ensure that there are no harmful effects on the human body.

### (6) Others

- This product is designed to be used for calibration. Do not use this product for any other purposes or other applications.
- The customer will not reverse engineer, disassemble or otherwise attempt to extract knowledge/design information from the LED.
- In the case of any incident, the local Nichia sales representative should be notified to discuss instructions on how to proceed while ensuring that the LED in question is not disassembled.
- All copyrights and other intellectual property rights in this specification in any form are reserved by Nichia or the right holders who have granted Nichia permission to use the content. Without prior written permission from Nichia, no part of this specification may be reproduced in any form or by any means.
- Both the customer and Nichia will agree on the official specifications for the supplied LEDs before any programs are officially launched. Without this agreement in writing (i.e. Customer Specific Specification), changes to the content of this specification may occur without notice (e.g. changes to the foregoing specifications and appearance, discontinuation of the LEDs, etc.).