

NICHIA CORPORATION

SPECIFICATIONS FOR WHITE LED

170 series

PART NO. **NJSW170HTx**

- NJSW170HT
- NJSW170HT-SA
(Fnwx Spec.)

Applications



NJSW170HT



NJSW170HT-SA

- Pb-free Reflow Soldering Application
- ESD Withstand Voltage (HBM) Class 3B
- RoHS Compliant
- IATF 16949 Compliant
- AEC-Q102 Qualified

FEATURES

L.E.S. lineups and color rank options are available to support the wide variety of lighting designs in the CSP family.

L.E.S. Lineups :

2W	NJSW170H	0.9 x 0.9mm	NJSW170H-SA	0.76 x 0.76mm	NJSW170H-SB	0.5 x 0.5mm
	NCSW170H, NCSW131H	1.15 x 1.15mm	NCSW170H-SA, NCSW131H-SA	0.95 x 0.95mm	NCSW170H-SB, NCSW131H-SB	0.76 x 0.76mm
3W	NCSW179H-D5, NCSW139H-D5		NCSW179H-D6, NCSW139H-D6			
	0.5 x 2.0mm		0.6 x 2.0mm			
6W	NC2W170H, NC2W121H		NC2W121H-SC			
	1.15 x 2.3mm		0.75 x 1.6mm			

The LED package of 131, 139, 121 series has a die heat sink pad that is electrically non-polar. By designing the PCBA with these pads in mind, the heat dissipation performance of the lighting fixtures can be maximized.

Color rank options :

In addition to the STANDARD ranks, PREMIUM and super focused ranks are available as an option.

Ordering ranks

STANDARD ranks starting with F in their rank name.

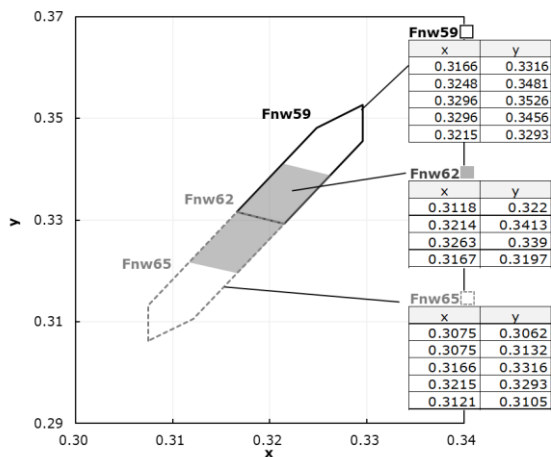

PREMIUM ranks starting with M in their rank name.

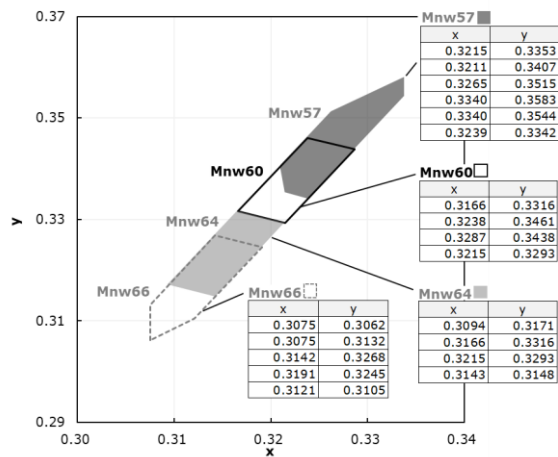

Super-focused ranks with separate reels

This is an **optional service available only for STANDARD ranks**. Super focused ranks can be shipped as separate reels. This can minimize color variation within the same fixture. In addition, the quantity ratio for these ranks cannot be specified. The single rank cannot be ordered.

Super-focused ranks

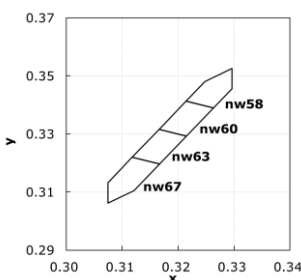

If you would like to order with this service, you can order each STANDARD ranks as below.

Fnw59 : " nw58/nw60 "
 Fnw62 : " nw60/nw63 "
 Fnw65 : " nw63/nw67 "

CONTENTS

SPECIFICATIONS..... 2

 (1) Absolute Maximum Ratings 2

 (2) Initial Electrical/Optical Characteristics 2

 (3) Thermal Resistance 2

 (4) Ranks 3

CHARACTERISTIC CURVES 5

 (1) Optical Characteristics 5

 (2) Forward Current Characteristics / Temperature Characteristics..... 6

DERATING CHARACTERISTICS 8

OUTLINE DIMENSIONS..... 9

 (1) NJSW170HTx 9

SOLDERING 10

TAPE AND REEL DIMENSIONS 12

PACKAGING - TAPE & REEL 13

LOT NUMBERING CODE 14

CAUTIONS..... 15

SPECIFICATIONS

(1) Absolute Maximum Ratings

Item	Symbol	Absolute Maximum Rating	Unit
Forward Current	I_F	800	mA
Pulse Forward Current	I_{FP}	2000	mA
ESD Withstand Voltage (HBM)	V_{ESD}	8	kV
Allowable Reverse Current	I_R	85	mA
Power Dissipation	P_D	2.87	W
Operating Temperature	T_{opr}	-40~135	°C
Storage Temperature	T_{stg}	-40~135	°C
Junction Temperature	T_J	150	°C

* Absolute Maximum Ratings at $T_J=25^{\circ}\text{C}$.

* HBM ESD Component Classification Level of the LEDs: Class 3B

For more details, see ANSI/ESDA/JEDEC JS-001.

* The operating Temperature range is the range of soldering temperature (T_S).

(2) Initial Electrical/Optical Characteristics

Item	Symbol	Part Number	Condition	Typ	Unit	
Forward Voltage	V_F	All 2 part numbers	$I_F=650\text{mA}$	3.25	V	
Luminous Flux	Φ_v	NJSW170HT	$I_F=650\text{mA}$	295	lm	
		NJSW170HT-SA	$I_F=650\text{mA}$	275		
Chromaticity Coordinate	x	-	All 2 part numbers	$I_F=650\text{mA}$	0.325	-
	y			$I_F=650\text{mA}$	0.342	

* Characteristics at $T_J=25^{\circ}\text{C}$, measured in a continuous square wave pulse mode with a pulse width of 0.05msec and a duty cycle of 1%.

* Luminous Flux value as per CIE 127:2007 standard.

* Chromaticity Coordinates as per CIE 1931 Chromaticity Chart.

(3) Thermal Resistance

Item	Symbol	Part Number	Typ	Max	Unit
Thermal Resistance	$R_{\theta JS_real}$	NJSW170HT	6.5	7.2	°C/W
	$R_{\theta JS_el}$		3.7	4.1	
	$R_{\theta JS_real}$	NJSW170HT-SA	6.5	7.2	
	$R_{\theta JS_el}$		3.9	4.5	

* Thermal resistance values ($R_{\theta JS_real}$) determined by considering the energy conversion efficiency below. Refer to JESD51.

- NJSW170HT : $\eta_e=43\%$

- NJSW170HT-SA : $\eta_e=40\%$

* The maximum values are obtained using the statistical dispersion (i.e. $+5\sigma$, σ stands for standard deviation).

(4) Ranks

Item	Part Number	Rank	Min	Max	Unit
Forward Voltage	All 2 part numbers	-	3.00	3.45	V
Luminous Flux	NJSW170HT	C295	295	310	lm
		C280	280	295	
		B270	270	280	
		C265	265	280	
		T260	260	265	
	NJSW170HT-SA	C280	280	295	
		C265	265	280	
		C250	250	265	
		T245	245	250	
		B240	240	250	

Luminous Flux Ranks by Color Rank

	NJSW170HT	NJSW170HT-SA
Fnw59	B270,C280,C295	C250,C265,C280
Fnw62	C265,C280,C295	T245,C250,C265,C280
Fnw65	T260,C265,C280,C295	B240,C250,C265

- * Ranks at T_j=25°C measured in a continuous square wave pulse mode with a pulse width of 0.05msec and a duty cycle of 1%.
- * Forward Voltage Tolerance: ±0.05V
- * Luminous Flux Tolerance: ±5%
- * LEDs from the above ranks will be shipped. The rank combination ratio per shipment will be decided by Nichia.

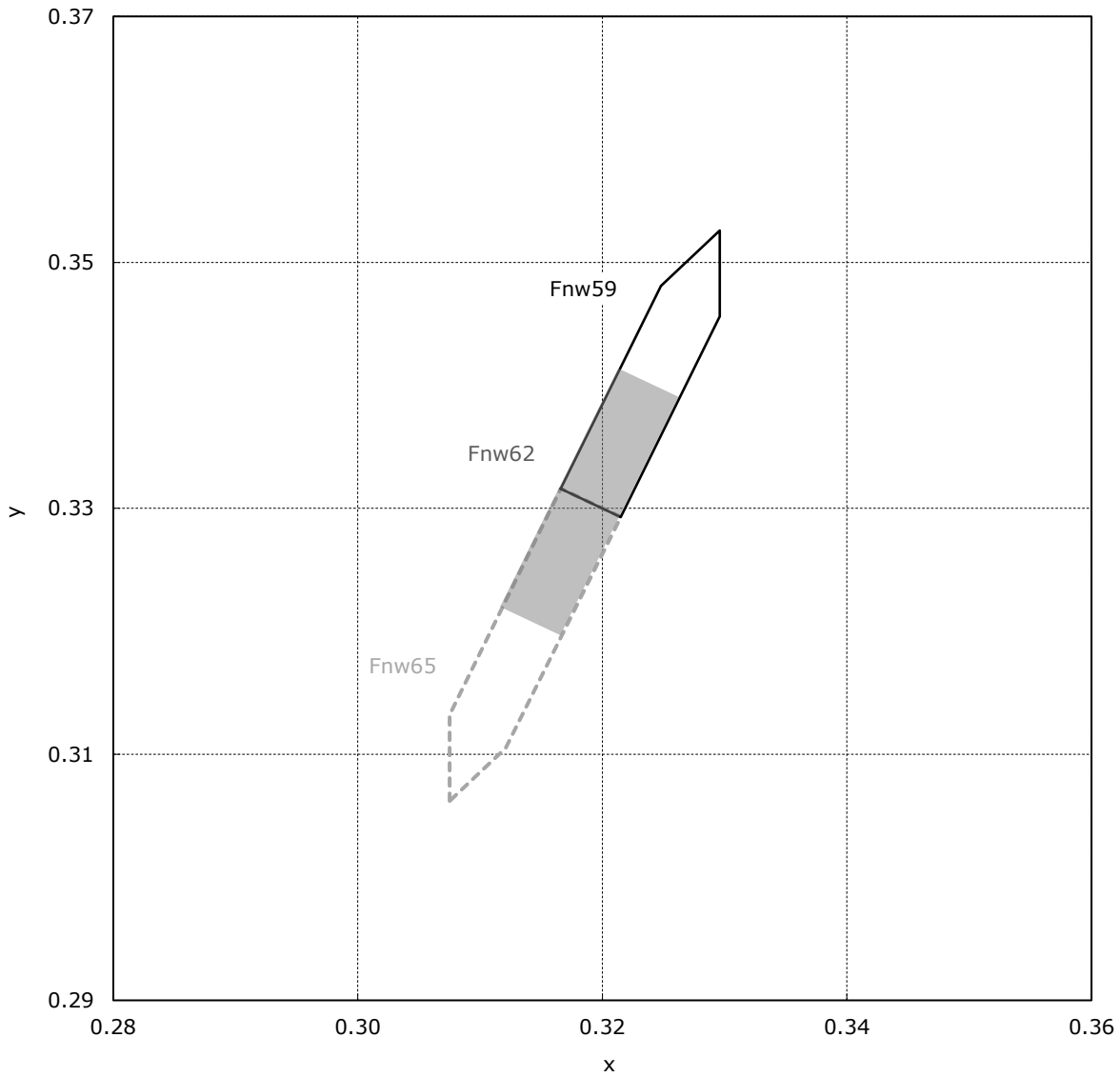

Color Ranks

	Rank Fnw59				
x	0.3166	0.3248	0.3296	0.3296	0.3215
y	0.3316	0.3481	0.3526	0.3456	0.3293

	Rank Fnw62			
x	0.3118	0.3214	0.3263	0.3167
y	0.3220	0.3413	0.3390	0.3197

	Rank Fnw65				
x	0.3075	0.3075	0.3166	0.3215	0.3121
y	0.3062	0.3132	0.3316	0.3293	0.3105

* Ranks at $T_j=25^{\circ}\text{C}$ measured in a continuous square wave pulse mode with a pulse width of 0.05msec and a duty cycle of 1%.

* Chromaticity Coordinate Tolerance: ± 0.003

* LEDs from the above ranks will be shipped. The rank combination ratio per shipment will be decided by Nichia.

CHARACTERISTIC CURVES

(1) Optical Characteristics

- * All characteristics shown are for reference only and are not guaranteed.
- * Characteristics measured in a continuous square wave pulse mode with a pulse width of 0.05msec and a duty cycle of 1%.

Part No. NJSW170Hx
No. STS-DA7-22893

Spectrum

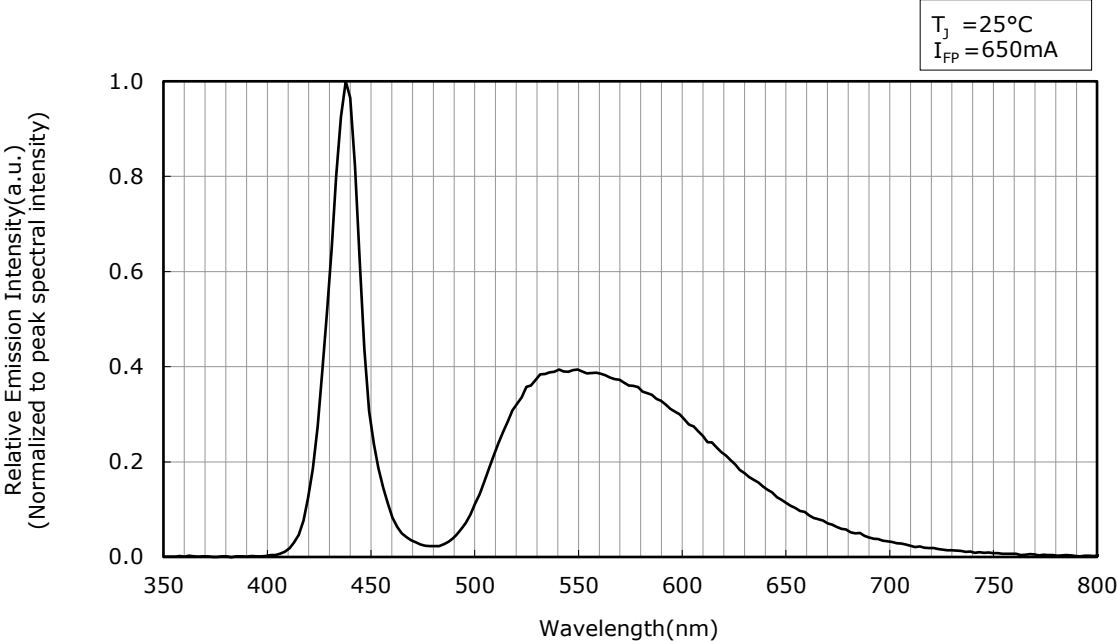

Directivity

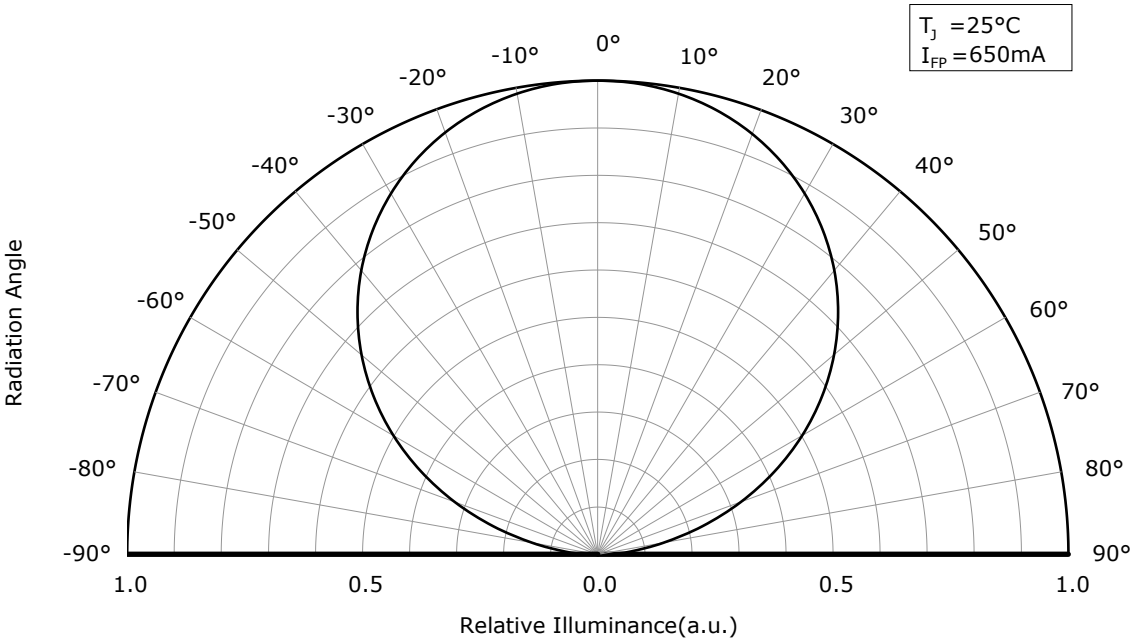

(2) Forward Current Characteristics / Temperature Characteristics

- * All characteristics shown are for reference only and are not guaranteed.
- * Characteristics measured in a continuous square wave pulse mode with a pulse width of 0.05msec and a duty cycle of 1%.

Part No. NJSW170Hx
No. STS-DA7-22894

Forward Voltage vs Forward Current

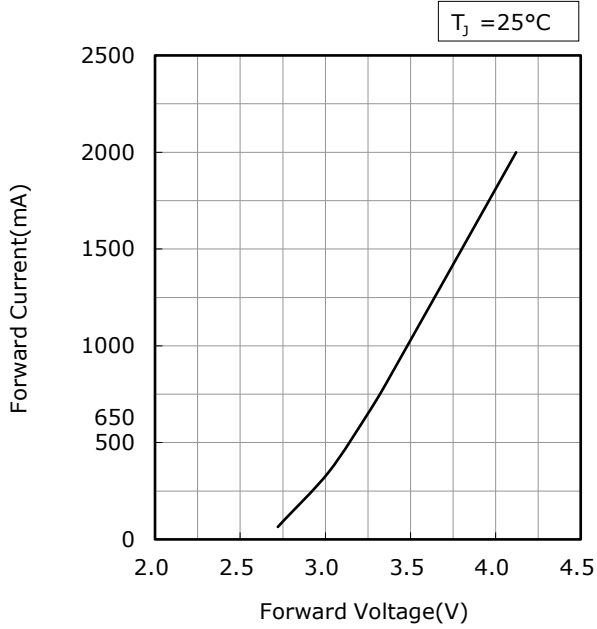

Junction Temperature vs Forward Voltage

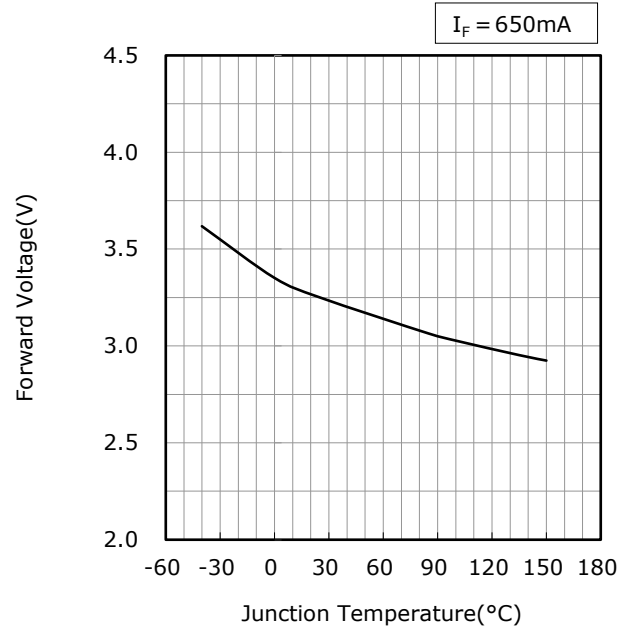

Forward Current vs Relative Luminous Flux

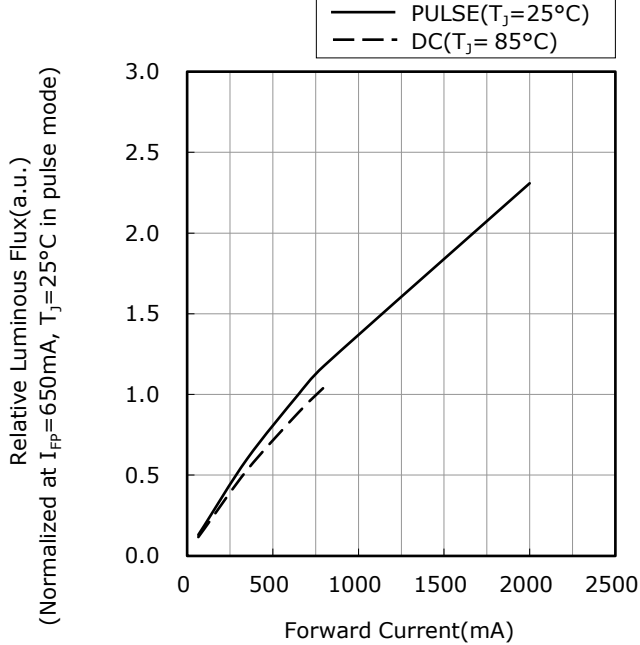

Junction Temperature vs Relative Luminous Flux

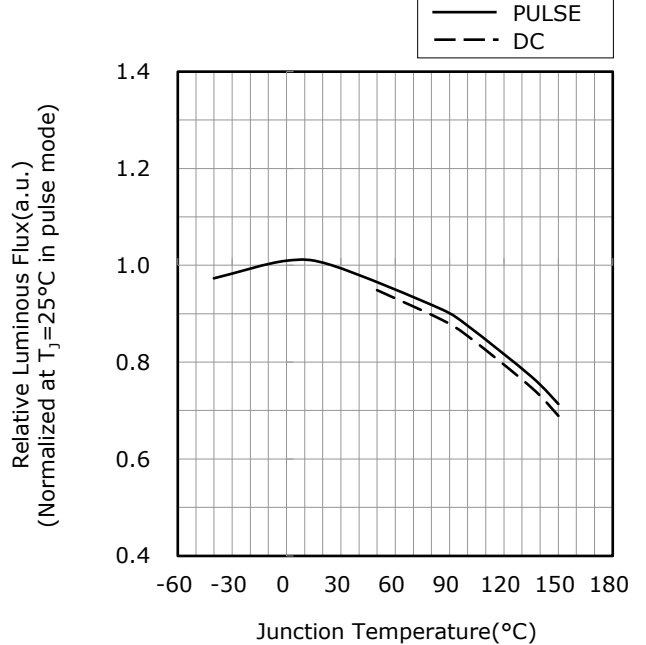

- * All characteristics shown are for reference only and are not guaranteed.
- * Characteristics measured in a continuous square wave pulse mode with a pulse width of 0.05msec and a duty cycle of 1%.
- * The following graphs show the characteristics moved the measurement value at $I_{FP}=650\text{mA}$, $T_J=25^\circ\text{C}$ in pulse mode to the center point of color rank.

Part No. NJSW170Hx
No. STS-DA7-22895

Forward Current vs Chromaticity Coordinate

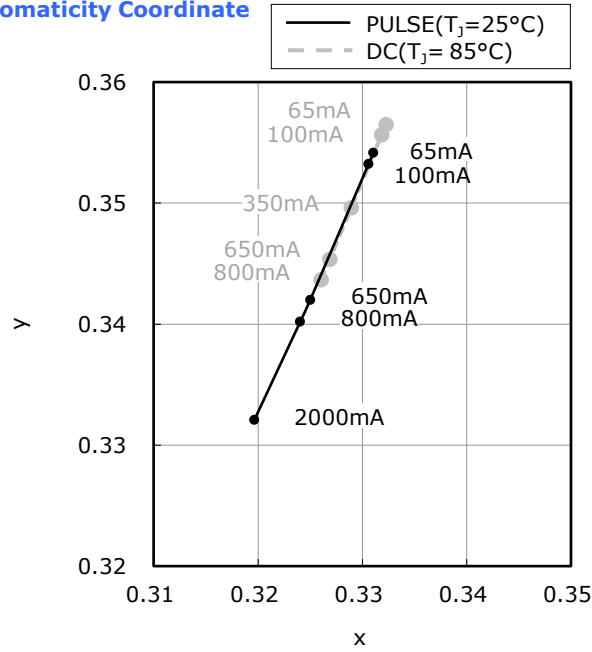

Junction Temperature vs Chromaticity Coordinate

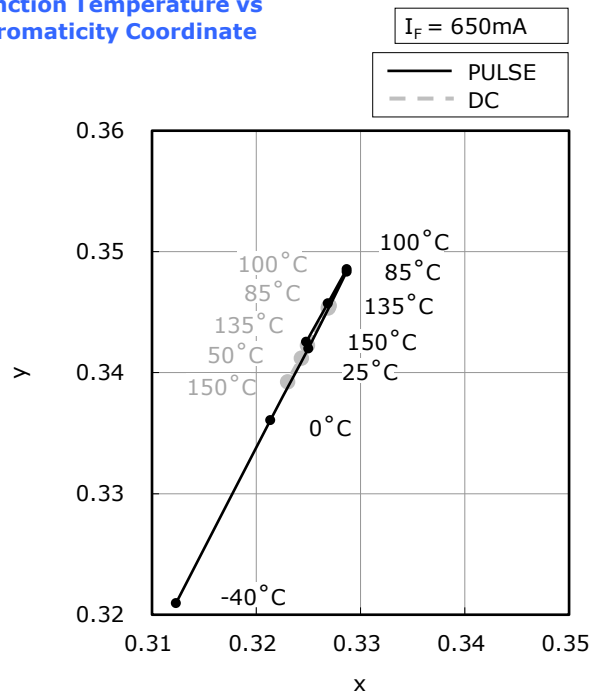

DERATING CHARACTERISTICS

Soldering Temperature (Cathode Side) vs Allowable Forward Current

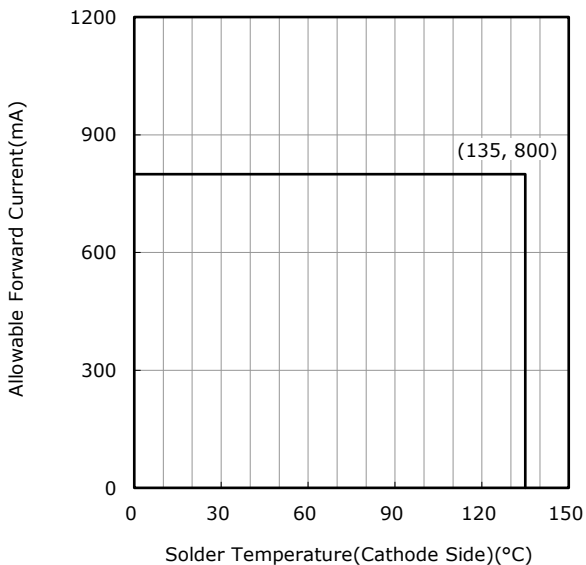

Pulse Width vs Allowable Forward Current

0°C ≤ T _s ≤ 135°C	
<div style="display: flex; justify-content: space-between; align-items: center;"> <div style="text-align: center;"> <p>— Duty 100%</p> <p>— Duty 5%</p> </div> <div style="text-align: center;"> <p>- - - Duty 50%</p> <p>..... Duty 2%</p> </div> <div style="text-align: center;"> <p>- - - Duty 20%</p> <p>- - - Duty 1%</p> </div> <div style="text-align: center;"> <p>- · - Duty 10%</p> <p>- · - Duty 0.5%</p> </div> </div>	
NJSW170HT	
NJSW170HT-SA	

OUTLINE DIMENSIONS

(1) NJSW170HTx

(Unit: mm, Tolerance: ±0.05)

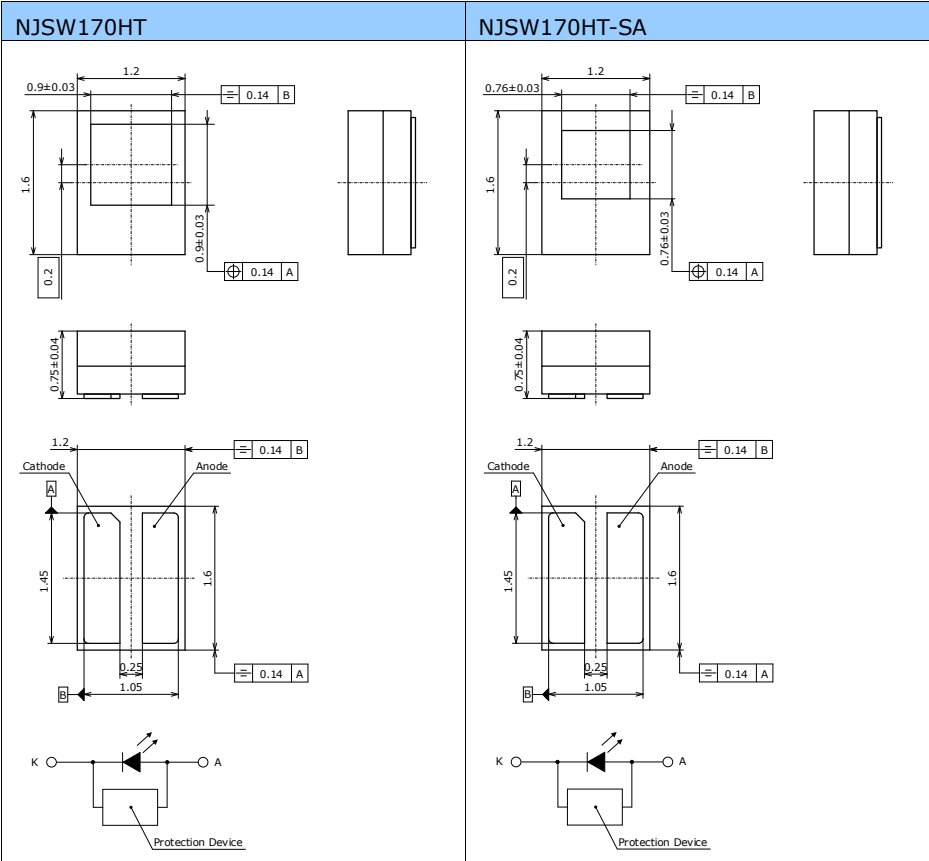

Item	Description	
Package Materials	Ceramics	
Phosphor Sheet Materials	Phosphor Ceramics	
Encapsulating Resin Materials	Silicone Resin	
Electrodes Materials	Au-plated	
Weight	NJSW170HT	NJSW170HT-SA
	0.0047	0.0046

- * Dimensions do not include mold flash.
- * The height of LED package is from the bottom of back electrode to the surface of emitting area.
- * This product complies with RoHS Directive.

SOLDERING

- Reflow Soldering Condition(Lead-free Solder)

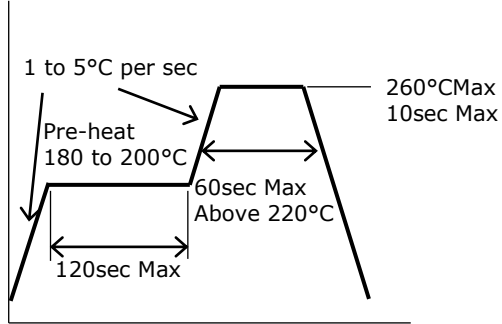

* This condition is for all the part numbers to which the specification applies.

- Recommended Soldering Pad Pattern

- NJSW170HT, NJSW170HT-SA

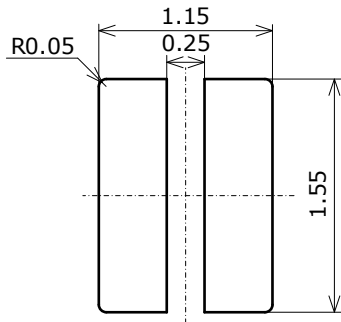

- Recommended Metal Solder Stencil Aperture

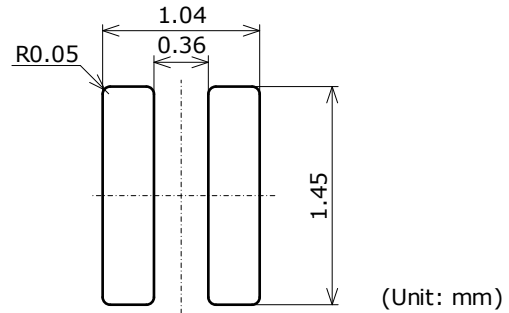

(Unit: mm)

- * This LEDs are designed to be reflow soldered to a PCB. If dip soldered or hand soldered, Nichia will not guarantee its reliability.
- * Reflow soldering must not be performed more than twice.
- * The reflow profile should be determined based on the recommended soldering conditions for the solder paste that is used.
- * When cooling the LEDs from the peak temperature a gradual cooling slope is recommended; do not cool the LEDs rapidly.
- * During reflow soldering, the heat and atmosphere in the reflow oven may cause the optical characteristics to degrade. In particular, reflow soldering performed with an air atmosphere may have a greater negative effect on the optical characteristics than if a nitrogen atmosphere is used; Nichia recommends using a nitrogen reflow atmosphere.

* These LEDs use ceramics for the phosphor sheet (i.e. emitting surface); if excess pressure is applied to the ceramics, it may cause the ceramics to be damaged, chipped, cracked and/or deformed. If the ceramics is damaged, chipped, cracked and/or deformed, it may cause the internal connection to fail causing a catastrophic failure (i.e. the LEDs not to illuminate) and/or reliability issues (e.g. the LEDs to corrode and/or to become dimmer, the color/directivity to change, etc.).

Recommended conditions:

Using a nozzle specifically designed for the LEDs is recommended (See the nozzle drawing below).

Nozzle contact area:

The center of the phosphor sheet (See the second figure from the right)

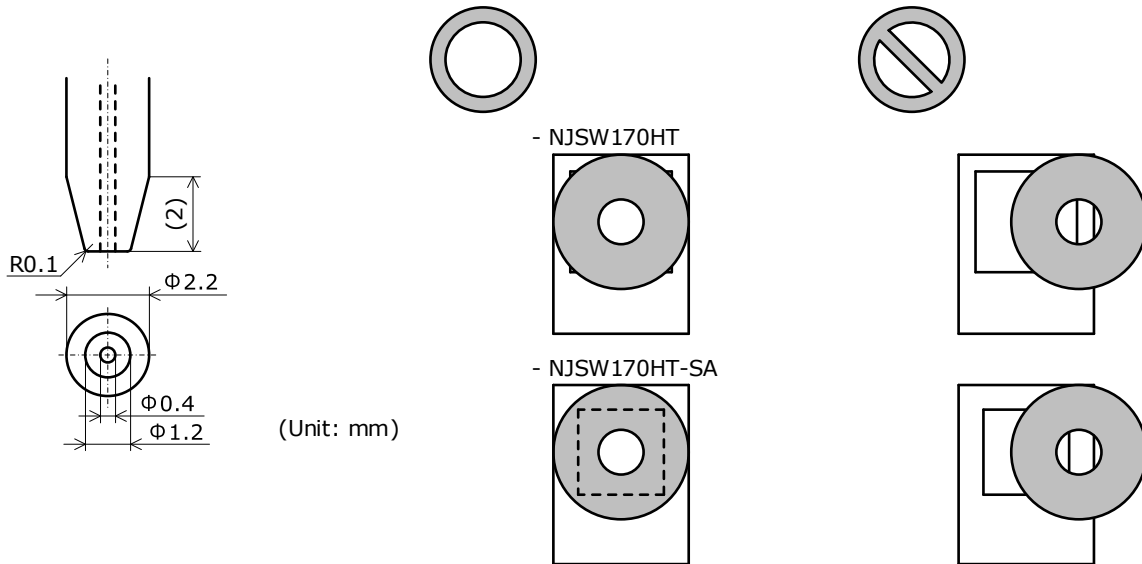

If the nozzle is off-center and makes contact with the edges of the phosphor sheet (as shown in the figure to the right), it may cause the ceramic to chip/crack.

Placement pressure $\leq 3.5\text{N/mm}^2$ *max. force: 5N

Vacuum pressure $\leq 8\text{N/cm}^2$ ($\leq 0.8\text{kgf/cm}^2$)

- * Once the LEDs have been soldered to a PCB, it should not be repaired/reworked. If it must be done, using a hot plate is strongly recommended. Sufficient verification should be performed prior to use to ensure that the repair/rework does not cause the LED characteristics to deteriorate.
- * When soldering, do not apply stress to the LEDs while the LEDs are hot.
- * When using a pick and place machine, choose an appropriate nozzle for the LEDs.
- * The soldering pad pattern above is a general recommendation for LEDs to be mounted without issues; if a high degree of precision is required for the chosen application (i.e. high-density mounting), ensure that the soldering pad pattern is optimized.
- * When flux is used, it should be a halogen free flux. Ensure that the manufacturing process is not designed in a manner where the flux will come in contact with the LEDs.
- * Ensure that there are no issues with the type and amount of solder that is being used.
- * These LEDs have all the electrodes on the backside; solder connections will not be able to be seen nor confirmed by a normal visual inspection. Ensure that sufficient verification is performed on the soldering conditions prior to use to ensure that there are no issues.

TAPE AND REEL DIMENSIONS

Tape

Part No. Nxxx170x
No. STS-DA7-22890

(Unit: mm)

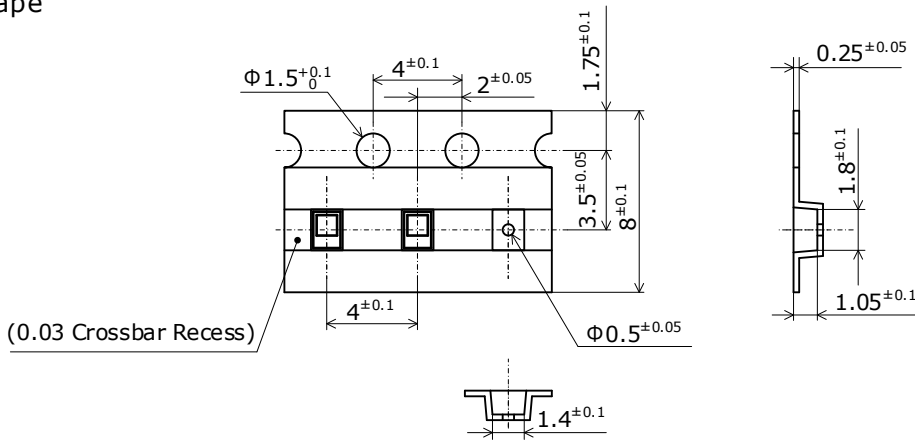

Trailer and Leader

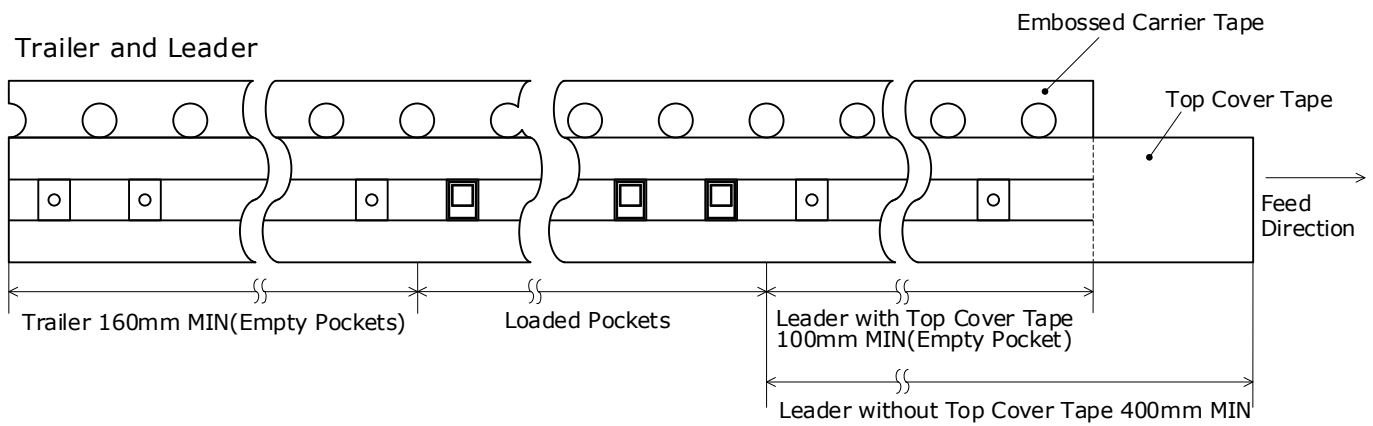

Reel

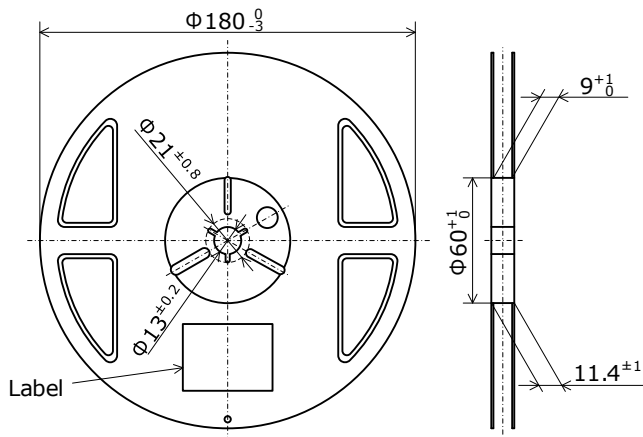

- * Reel Size: 3500pcs
- * When the tape is rewound due to work interruptions, no more than 10N should be applied to the embossed carrier tape. The LEDs may stick to the top cover tape.
- * The tape packing method complies with JIS C 0806 (Packaging of Electronic Components on Continuous Tapes).

PACKAGING - TAPE & REEL

Reels are shipped with desiccants in heat-sealed moisture-proof bags.

Part No. Nxxxxxxx
No. STS-DA7-21831

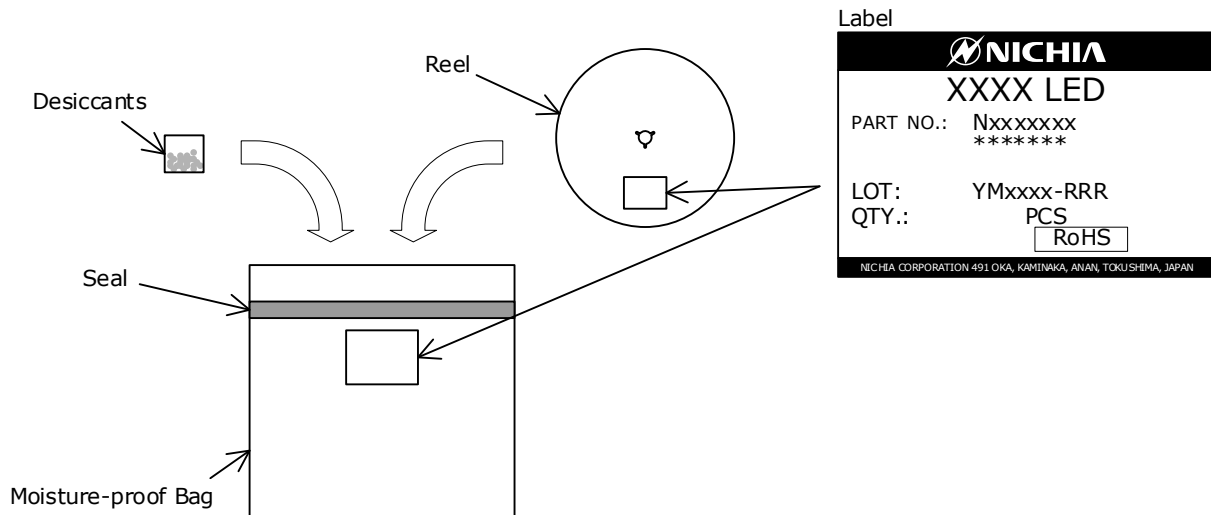

Moisture-proof bags are packed in cardboard boxes with corrugated partitions.

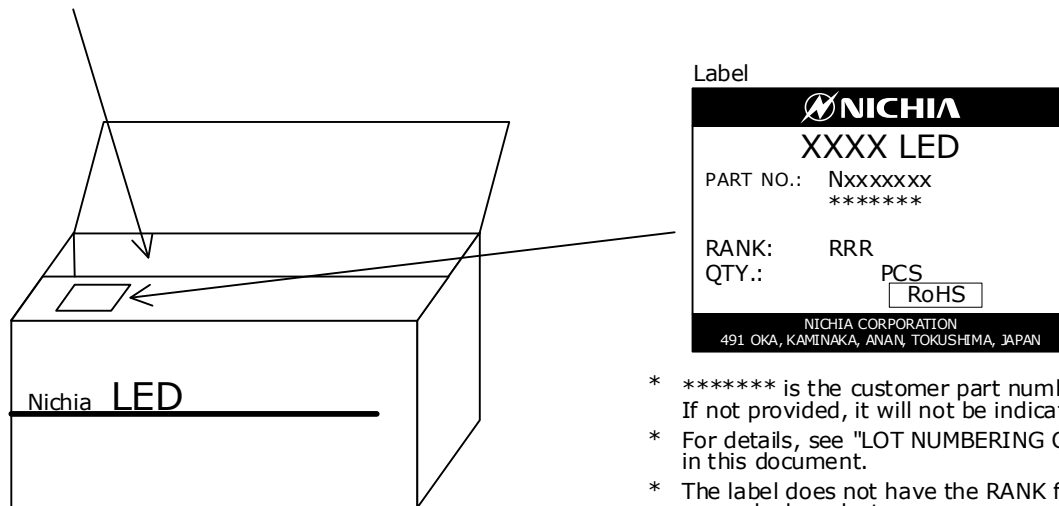

- * ***** is the customer part number. If not provided, it will not be indicated on the label.
- * For details, see "LOT NUMBERING CODE" in this document.
- * The label does not have the RANK field for un-ranked products.

- * Products shipped on tape and reel are packed in a moisture-proof bag. They are shipped in cardboard boxes to protect them from external forces during transportation.
- * Do not drop or expose the box to external forces as it may damage the products.
- * Do not expose to water. The box is not water-resistant.
- * Using the original package material or equivalent in transit is recommended.

LOT NUMBERING CODE

Lot Number is presented by using the following alphanumeric code.

YMxxxx - RRR

Y - Year

Year	Y
2025	P
2026	Q
2027	R
2028	S
2029	T
2030	U

Thereafter, a letter of the alphabet is assigned to each year in alphabetical order.

M - Month

Month	M	Month	M
1	1	7	7
2	2	8	8
3	3	9	9
4	4	10	A
5	5	11	B
6	6	12	C

xxxx-Nichia's Product Number

RRR-Ranking by Color Coordinates, Ranking by Luminous Flux

CAUTIONS

(1) Storage

	Conditions	Temperature	Humidity	Time
Storage	Before Opening Aluminum Bag	≤30°C	≤90%RH	Within 1 Year from Delivery Date
	After Opening Aluminum Bag	≤30°C	≤70%RH	≤1year

- The storage/packaging requirements for the LEDs are comparable to JEDEC Moisture Sensitivity Level (MSL) 2 or equivalent. Nichia used IPC/JEDEC STD-020 as a reference to rate the MSL of the LEDs.
- These LEDs use a package that could absorb moisture; if the package absorbs moisture and is exposed to heat during soldering, it may cause the moisture to vaporize and the package to expand and the resulting pressure may cause internal delamination. This may cause the optical characteristics to degrade. To minimize moisture absorption in storage/transit, moisture-proof aluminum bags are used for the LEDs with a silica gel packet to absorb any air moisture in the bag. The silica gel beads turn blue to red as they absorb moisture.
- Once the moisture-proof aluminum bag is open, ensure that the LEDs are soldered to a PCB within the range of the conditions above. To store any remaining unused LEDs, use a hermetically sealed container with silica gel desiccants. Nichia recommends placing them back to the original moisture-proof bag and reseal it.
- The parts/materials (e.g. housing, gasket/seal, secondary lens, lens cover, thermal grease, etc.) used with the LEDs in the same assembly/system may release corrosive gases containing sulfur, halogens, etc. A light-up test, sufficient verifications, etc. must be performed at the finished product level (i.e. automotive headlamp, luminaire, etc.) prior to use taking into consideration the conditions/environments in which the finished product will actually be used to ensure that the expected performance for the finished product is maintained. See below for the detailed information.

Issues that may be caused by corrosive gases containing sulfur, halogens, etc.:

These LEDs have plated parts. If the LEDs are exposed to corrosive gases containing sulfur, halogens, etc., it may cause the plated surface to tarnish. If the gases penetrate the LEDs (e.g. emitting surface, package material, etc.), it may cause the surface of the plated parts inside the package to tarnish. In addition, it has been confirmed that if a silicone resin is used in the LEDs, the gases may accelerate degradation of the silicone resin. As a result, the optical characteristics may be adversely affected (i.e. significant reduction in the brightness, significant color shift, etc.); in the worst case, the circuit could become open causing a catastrophic failure (i.e. the LEDs not to illuminate). When determining the storage environment for the LEDs and/or selecting parts/materials that will be used with the LEDs in the finished product, it must be ensured prior to use that corrosive gases containing sulfur, halogens, etc. are not generated.

- To avoid condensation, the LEDs must not be stored in areas where temperature and humidity fluctuate greatly.
- Do not store the LEDs in a dusty environment.
- Do not expose the LEDs to direct sunlight and/or an environment over a long period of time where the temperature is higher than normal room temperature.

(2) Directions for Use

- The circuit must be designed to ensure that the Absolute Maximum Ratings are not exceeded for each LED. The LEDs should be operated at a constant current per LED. In the case of operating at a constant voltage, Circuit B is recommended. If Circuit A is used, it may cause the currents flowing through the LEDs to vary due to the variation in the forward voltage characteristics of the LEDs on the circuit.

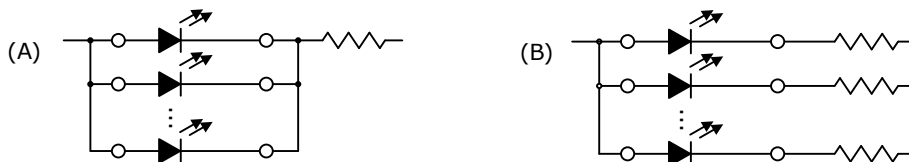

- These LEDs are designed to be operated at a forward current. Ensure that no voltage is applied to the LEDs in the forward/reverse direction while the LEDs are off. If the LEDs are used in an environment where reverse voltages are applied to the LEDs continuously, it may cause electrochemical migration to occur causing the LEDs to be damaged. When not in use for a long period of time, the system's power should be turned off to ensure that there are no issues/damage.
- To stabilize the LED characteristics while in use, Nichia recommends that the LEDs are operated at currents $\geq 10\%$ of the sorting current.
- Ensure that transient excessive voltages (e.g. lightning surge) are not applied to the LEDs.
- If the LEDs are used for outdoor applications, ensure that necessary measures are taken (e.g. protecting the LEDs from water/salt damage and high humidity).

(3) Handling Precautions

- Do not handle the LEDs with bare hands as it will contaminate the LED surface and may affect the optical characteristics: it might cause the LEDs to be deformed and/or the bump to break, which will cause the LEDs not to illuminate.
- Ensure that when handling the LEDs with tweezers, excessive force is not applied to the LEDs. Otherwise, it may cause damage to the resin (e.g. cut, scratch, chip, crack, delamination and deformation) and the internal connection to fail causing a catastrophic failure (i.e. the LEDs not to illuminate).
- Dropping may cause damage to the LEDs (e.g. deformation).
- Do not stack assembled PCBs together. Otherwise, it may cause damage to the resin (e.g. cut, scratch, chip, crack, delamination and deformation) and the internal connection to fail causing a catastrophic failure (i.e. the LEDs not to illuminate).

(4) Design Consideration

- If the LEDs are soldered to a PCB and the PCB assembly is bent (e.g. PCB depaneling process), it may cause the LED package to break. The PCB layout should be designed to minimize the mechanical stress on the LEDs when the PCB assembly is bent/warped.
- The amount of mechanical stress exerted on the LEDs from depaneling may vary depending on the LED position/orientation on the PCB assembly (e.g. especially in areas near V-groove scores). The PCB layout should be designed to minimize the mechanical stress on the LEDs when the PCB is separated into individual PCB assemblies.
- To separate a PCB populated with the LEDs, use a specially designed tool. Do not break the PCB by hand.
- The parts/materials (e.g. housing, gasket/seal, secondary lens, lens cover, thermal grease, etc.) used with the LEDs in the same assembly/system may release corrosive gases containing sulfur, halogens, etc., and/or volatile organic compounds (VOCs). A light-up test, sufficient verifications, etc. must be performed at the finished product level (i.e. automotive headlamp, luminaire, etc.) prior to use taking into consideration the conditions/environments in which the finished product will actually be used to ensure that the expected performance for the finished product is maintained. See below for the detailed information.

Issues that may be caused by corrosive gases containing sulfur, halogens, etc.:

These LEDs have plated parts. If the LEDs are exposed to corrosive gases containing sulfur, halogens, etc., it may cause the plated surface to tarnish. If the gases penetrate the LEDs (e.g. emitting surface, package material, etc.), it may cause the surface of the plated parts inside the package to tarnish. In addition, it has been confirmed that if a silicone resin is used in the LEDs, the gases may accelerate degradation of the silicone resin. As a result, the optical characteristics may be adversely affected (i.e. significant reduction in the brightness, significant color shift, etc.); in the worst case, the circuit could become open causing a catastrophic failure (i.e. the LEDs not to illuminate). When determining the storage environment for the LEDs and/or selecting parts/materials that will be used with the LEDs in the finished product, it must be ensured prior to use that corrosive gases containing sulfur, halogens, etc. are not generated.

Issues that may be caused by VOCs:

If VOCs that have been released from the parts/materials and/or organic additives used with the LEDs in the finished product penetrate into the LEDs and remain inside the LEDs, the VOCs can discolor after being exposed to heat and/or photon energy. This may cause the optical characteristics to be adversely affected (i.e. significant reduction in the brightness, significant color shift, etc.). This adverse effect may be improved by ventilating the environment (i.e. the LEDs are not used in a hermetically sealed environment) to prevent the VOCs from remaining inside the LEDs. When selecting parts/materials that will be used with the LEDs in the finished product, it must be ensured prior to use that there are no issues with the substances found in those parts/materials and/or that the expected performance for the finished product is maintained by performing a light-up test, sufficient verifications etc. taking into consideration the conditions/environments in which the finished product will actually be used.

- If the solder paste and/or the PCB (e.g. base material, insulation material, soldering pad patterns, etc.) are not appropriate, it may cause thermal stress in the solder joints resulting in cracks. A thorough verification should be performed with the chosen solder paste and PCB prior to use to ensure there are no issues, this verification should be performed taking into consideration the conditions/environments in which the end-product containing these LEDs will actually be used.
- If a metal-core PCB is used to operate the LEDs, it may cause thermal stress during operation causing damage to the solder joints (e.g. crack). Ensure that sufficient verification is performed prior to use. Nichia recommends using a metal-core PCB with a low elastic modulus insulating layer.
- Ensure that the chosen soldering pad pattern has a solder mask which does not cover the copper pads that the LEDs will be attached to or the area underneath the LEDs.

(Non Solder Mask Defined [NSMD] pads are recommended; see the figure below.)

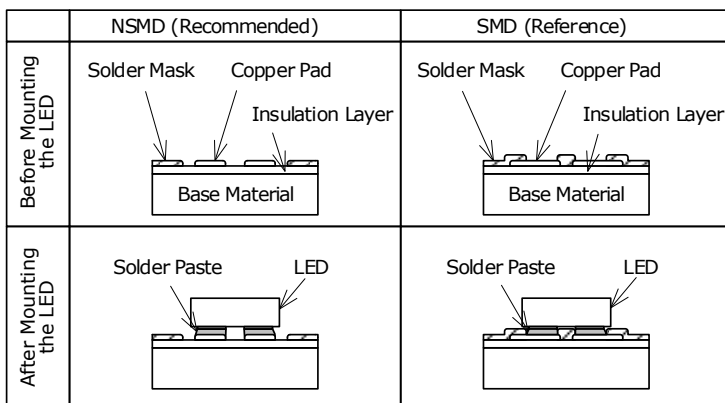

(5) Electrostatic Discharge (ESD)

- The LEDs are sensitive to transient excessive voltages (e.g. ESD, lightning surge). If this excessive voltage occurs in the circuit, it may cause the LEDs to be damaged causing issues (e.g. the LEDs to become dimmer or not to illuminate [i.e. catastrophic failure]).
Ensure that when handling the LEDs, necessary measures are taken to protect them from an ESD discharge. The following examples are recommended measures to eliminate the charge:
 - Grounded wrist strap, ESD footwear, clothes, and floors
 - Grounded workstation equipment and tools
 - ESD table/shelf mat made of conductive materials
- Ensure that all necessary measures are taken to prevent the LEDs from being exposed to transient excessive voltages (e.g. ESD, lightning surge):
 - tools, jigs, and machines that are used are properly grounded
 - appropriate ESD materials/equipment are used in the work area
 - the system/assembly is designed to provide ESD protection for the LEDs
- If the tool/equipment used is an insulator (e.g. glass cover, plastic, etc.), ensure that necessary measures have been taken to protect the LEDs from transient excessive voltages (e.g. ESD). The following examples are recommended measures to eliminate the charge:
 - Dissipating static charge with conductive materials
 - Preventing charge generation with moisture
 - Neutralizing the charge with ionizers
- To detect if an LED was damaged by transient excess voltages (i.e. an ESD event during the system's assembly process), perform a characteristics inspection (e.g. forward voltage measurement, light-up test) at low current ($\leq 1\text{mA}$).
- Failure Criteria: $V_F < 2.0\text{V}$ at $I_F = 0.5\text{mA}$
If the LEDs are damaged by transient excess voltages (e.g. ESD), it will cause:
 - the Forward Voltage (V_F) to decrease
 - the LEDs not to illuminate at a low current

(6) Thermal Management

- The Absolute Maximum Junction Temperature (T_J) must not be exceeded under any circumstances. The increase in the temperature of an LED while in operation may vary depending on the PCB thermal resistance and the density of LEDs on the PCB assembly. Ensure that when using the LEDs for the chosen application, heat is not concentrated in an area and properly managed in the system/assembly.
- The operating current should be determined by considering the temperature conditions surrounding the LEDs (i.e. T_A). Ensure that when operating the LEDs, proper measures are taken to dissipate the heat.
- The chosen thermal design must ensure that the Absolute Maximum Junction Temperature (T_J) will not be exceeded. Nichia recommends that the maximum values for the thermal resistances provided in the SPECIFICATIONS section under "Thermal Resistance" and the highest input power being used under the chosen conditions are taken into consideration for the thermal design. If they are not taken into consideration, perform sufficient verification prior to use under the actual operating conditions/environments where the LEDs will be used to ensure that there will be no issues with the chosen thermal design.

(7) Cleaning

- Do not clean the LEDs with water, benzine and/or thinner.
- To clean the LEDs, use isopropyl alcohol (IPA). If another solvent is used, it may cause the LED package/resin to be damaged causing issues; ensure that sufficient verification is performed prior to use. Additionally, ensure that the solvent being used does not cause any other issues (e.g. CFC-based solvents are heavily regulated).
- If an LED is contaminated (e.g. dust/dirt), use a cloth soaked with isopropyl alcohol (IPA). Ensure that the cloth is firmly squeezed before wiping the LED.
- Do not clean the LEDs with an ultrasonic cleaner. If cleaning must be done, ensure that sufficient verification is performed by using a finished assembly with the LEDs to determine cleaning conditions (e.g. ultrasonic power, LED position on the PCB assembly) that do not cause an issue.

(8) Eye Safety

- There may be two important international specifications that should be noted for safe use of the LEDs: IEC 62471:2006 Photobiological safety of lamps and lamp systems and IEC 60825-1:2001 (i.e. Edition 1.2) Safety of Laser Products - Part 1: Equipment Classification and Requirements. Ensure that when using the LEDs, there are no issues with the following points:
 - LEDs have been removed from the scope of IEC 60825-1 since IEC 60825-1:2007 (i.e. Edition 2.0) was published. However, depending on the country/region, there are cases where the requirements of the IEC 60825-1:2001 specifications or equivalent must be adhered to.
 - LEDs have been included in the scope of IEC 62471:2006 since the release of the specification in 2006.
 - Most Nichia LEDs will be classified as the Exempt Group or Risk Group 1 according to IEC 62471:2006. However, in the case of high-power LEDs containing blue wavelengths in the emission spectrum, there are LEDs that will be classified as Risk Group 2 depending on the characteristics (e.g. radiation flux, emission spectrum, directivity, etc.)
 - If the LEDs are used in a manner that produces an increased output or with an optic to collimate the light from the LEDs, it may cause damage to the human eye.
- If an LED is operated in a manner that emits a flashing light, it may cause health issues (e.g. visual stimuli causing eye discomfort). The system should be designed to ensure that there are no harmful effects on the human body.

(9) Miscellaneous

- If the LEDs are used under conditions/environments deviating from or inconsistent with those described in this specification, the resulting damage and/or injuries will not be covered.
- It is the customer's responsibility to perform sufficient verification prior to use to ensure that the lifetime and other quality characteristics required for the intended use are met.
- The applicable warranty period is one year from the date that the LEDs are delivered. In the case of any incident that appears to be in breach of this warranty, the local Nichia sales representative should be notified to discuss instructions on how to proceed while ensuring that the LED in question is not disassembled or removed from the PCB if it has been attached to the PCB. If a breach of this warranty is proved, Nichia will provide the replacement for the non-conforming LED or an equivalent item at Nichia's discretion. FOREGOING ARE THE EXCLUSIVE REMEDIES AVAILABLE TO THE CUSTOMER IN RESPECT OF THE BREACH OF THE WARRANTY CONTAINED HEREIN, AND IN NO EVENT SHALL NICHIA BE RESPONSIBLE FOR ANY INDIRECT, INCIDENTAL OR CONSEQUENTIAL LOSSES AND/OR EXPENSES (INCLUDING LOSS OF PROFIT) THAT MAY BE SUFFERED BY THE CUSTOMER ARISING OUT OF A BREACH OF THE WARRANTY.
- NICHIA DISCLAIMS ALL OTHER WARRANTIES, EXPRESS OR IMPLIED, INCLUDING THE IMPLIED WARRANTIES OF MERCHANTABILITY AND FITNESS FOR A PARTICULAR PURPOSE.
- The LEDs are intended to be used for general lighting, household appliances, electronic devices (e.g. mobile communication devices) and automobiles; the LEDs are not designed or manufactured for use in applications that require safety critical functions (e.g. aircraft, combustion equipment, life support systems, nuclear reactor control system, safety devices, spacecraft, submarine repeaters, traffic control equipment, trains, vessels, etc.). If the LEDs are planned to be used for these applications, unless otherwise detailed in the specification, Nichia will neither guarantee that the LEDs are fit for that purpose nor be responsible for any resulting property damage, injuries and/or loss of life/health.
- The customer will not reverse engineer, disassemble or otherwise attempt to extract knowledge/design information from the LEDs.
- All copyrights and other intellectual property rights in this specification in any form are reserved by Nichia or the right holders who have granted Nichia permission to use the content. Without prior written permission from Nichia, no part of this specification may be reproduced in any form or by any means.
- Both the customer and Nichia will agree on the official specifications for the supplied LEDs before any programs are officially launched. Without this agreement in writing (i.e. Customer Specific Specification), changes to the content of this specification may occur without notice (e.g. changes to the foregoing specifications and appearance, discontinuation of the LEDs, etc.).