

Part No. **NUBC32T**

Features

- Typical Optical Output Power: 13W
- Typical Dominant Wavelength: 465nm
- Multi-transverse Mode
- Fast Axis Collimated Beam

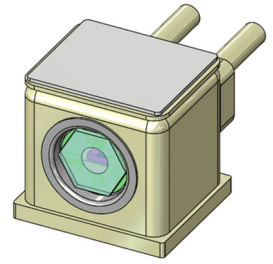

Absolute Maximum Ratings

Item	Symbol	Absolute Maximum Ratings	Unit
Forward Current ^{1,2}	I_F	Figure 1	A
Allowable Reverse Current	I_R	85	mA
Storage Temperature	T_{stg}	-40 ~ 85	°C
Operating Temperature ¹	T_B	15 ~ 55	°C

¹ See the schematic diagram of the temperature measurement point.

² The maximum rating provided in Figure 1 should not be exceeded.

As the forward current and/or the operating case temperature become higher, the lifetime of the LD will become shorter.

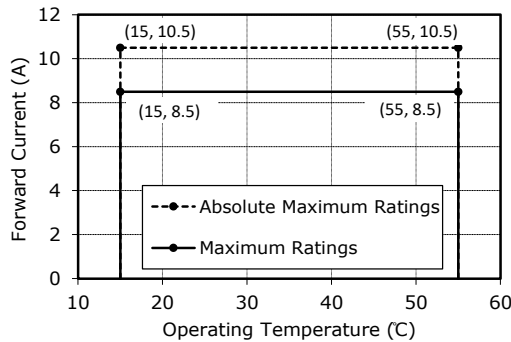

Figure 1. Derating Characteristics

Initial Electrical/Optical Characteristics^{3,4}

Item	Symbol	Condition	Min	Typ.	Max	Unit	
Optical Output Power	P_O	$I_F=8.5A$	11.5	(13.0)	16.0	W	
Dominant Wavelength	λ_d	$I_F=8.5A$	457	(465)	473	nm	
Threshold Current	I_{th}	-	-	(0.8)	1.1	A	
Slope Efficiency	η	-	-	(1.7)	-	W/A	
Forward Voltage	V_F	$I_F=8.5A$	3.5	(3.9)	4.3	V	
Beam Divergence ⁵	Parallel	$\theta_{//}$	$I_F=8.5A$	7.0	(10.0)	13.0	°
	Perpendicular	θ_{\perp}	$I_F=8.5A$	-	(0.16)	0.40	°
Beam Pointing Accuracy	Perpendicular	$\Delta\theta_{\perp}$	$I_F=8.5A$	-2.5	-	2.5	°

³ Characteristics values are values measured under Nichia's measurement conditions/environments; there may be variations for the measurement repeatability/reproducibility of these values. The values in parentheses are for reference purposes only.

⁴ Characteristics at $T_C = 20^{\circ}C$, equivalent to $T_B = 38^{\circ}C$ and measured in CW mode.

⁵ Full angle at $1/e^2$ from peak intensity

**This model is a Test Sample for evaluation or design purposes only. Lifetime is not guaranteed.
The above specifications are for reference purposes only and are subject to change without prior notice.**

NICHIA CORPORATION

◆ HEADQUARTERS

491 Oka, Kaminaka-Cho, Anan-Shi, TOKUSHIMA 774-8601, JAPAN
PHONE: +81-884-22-2311 FAX: +81-884-21-0148

◆ CONTACT

TOKYO SALES OFFICE
13F Tamachi Center Building 34-7, Shiba 5-Chome, Minato-ku, TOKYO 108-0014, JAPAN
PHONE: +81-3-3456-3746 FAX: +81-3-5440-7516

■ Outline Dimension

(Unit: mm)

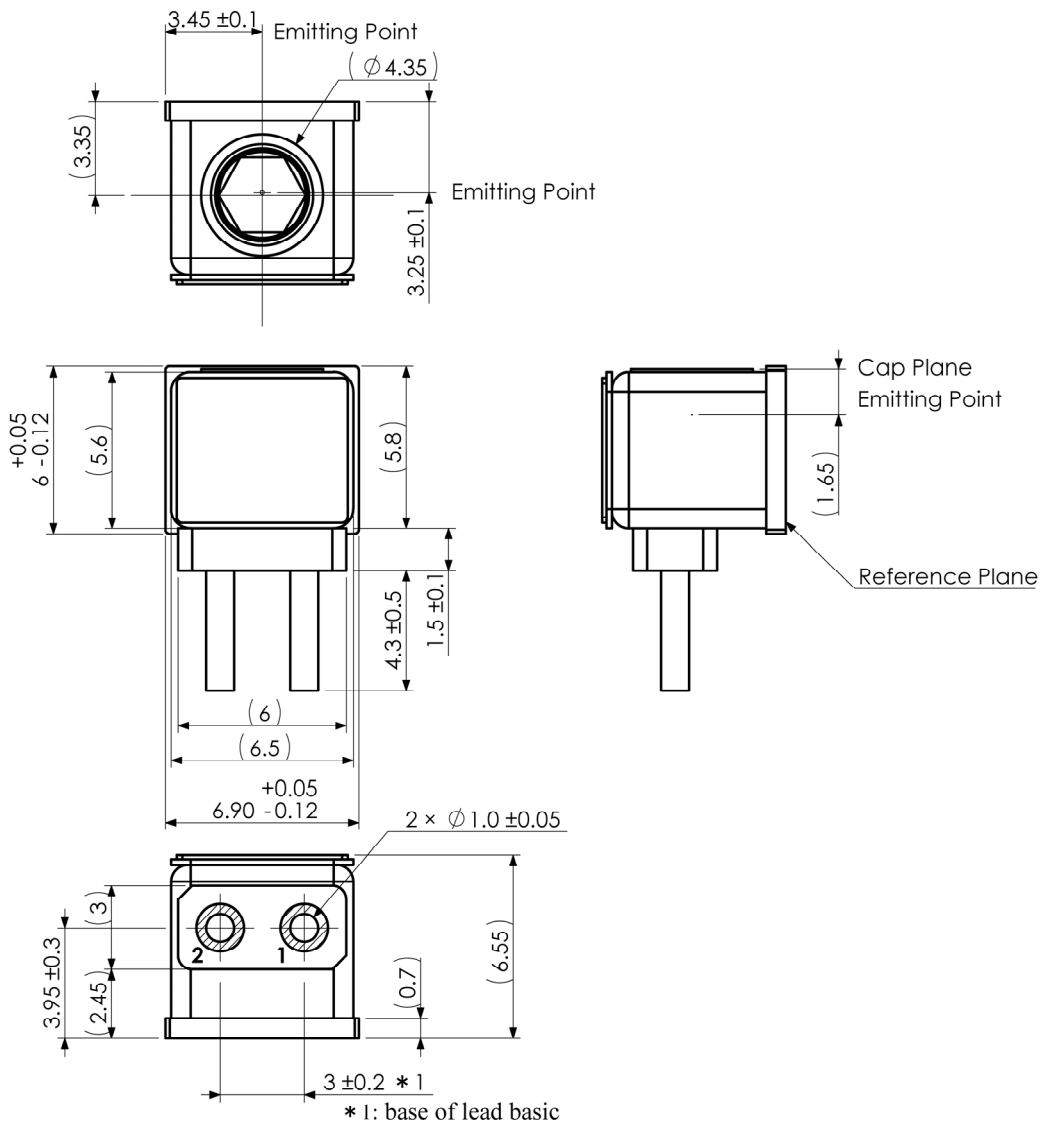

The dimension(s) in parentheses are for reference purposes.

■ Drive Circuit

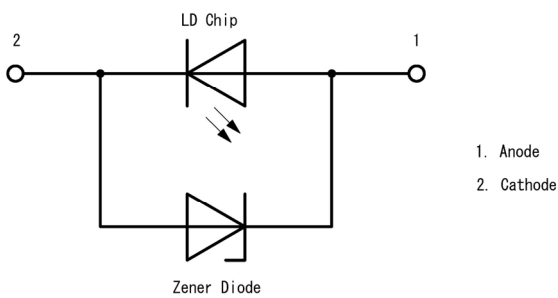

This LD has a Zener Diode built in as a protection circuit against static electricity.

■ $T_C = 20^\circ\text{C}, T_B = 38^\circ\text{C} (I_F=8.5\text{A})$

■ Schematic diagram of the temperature measurement point

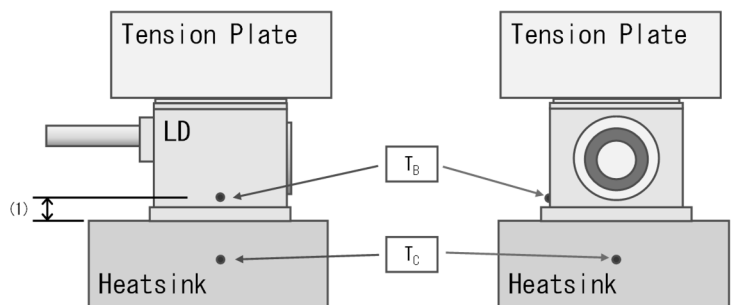

Unit : mm

■ Cautions

(1) Laser Hazard

- This LD is a laser diode classified as Class 4 per JIS C 6802, IEC 60825-1, and FDA/CDRH 21 CFR Part 1040.10; this is the most hazardous class. Ensure that the latest editions of IEC 60825-1 and/or applicable standards for general safety requirements and guidance for laser products are complied with.
- There is a risk of serious injury to the skin/eyes if they are exposed to the LD light. Even diffused/reflected light is harmful. It must be ensured that the maximum permissible exposure is not exceeded; use proper safety glasses for the wavelength and optical output power of the LD.
- This LD emits collimated light. Collimated light propagates over a long distance while maintaining a high energy density; the skin/eyes must not be exposed to the light.

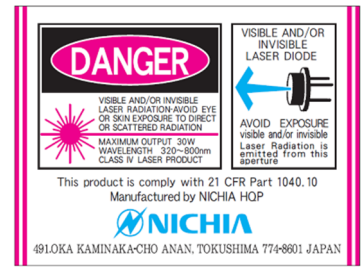

(2) Storage

- To avoid condensation, the LDs must not be stored in areas where temperature and humidity fluctuate greatly both before and after opening the antistatic, moisture-proof bag. The LDs must be stored under an environment of 5-35°C, 40-75% RH.
- This LD has plated parts. If the LDs are exposed to a corrosive environment, it may cause the plated surface to tarnish causing issues (e.g. electric connection failures). Once the antistatic, moisture-proof bag is opened, ensure that the LDs are assembled into the chosen application/heatsink immediately; if they are not used immediately, they must be stored in a hermetically sealed container (e.g. the original antistatic, moisture-proof bag).
- Do not store the LDs in a dusty environment.
- Do not expose the LDs to direct sunlight and/or an environment over a long period of time where the temperature is higher than normal room temperature.

(3) Design Consideration

- This LD is a semiconductor device that has a high current density during operation in the emission layer. Exceeding the Absolute Maximum Ratings may damage the LD. The circuit must be designed to ensure that the Absolute Maximum Ratings (see Absolute Maximum Ratings and Figure 1) are not exceeded even if the LDs are operated only for a short period of time.
- Since the lifetime of the LD will become shorter as the operating current and/or the optical output power becomes larger, the maximum ratings provided in Figure 1 should not be exceeded.
- This LD should be operated in an automatic current control (ACC) circuit. Additionally, the circuit to operate the LDs should be designed taking into consideration the current rise time. If no measures are incorporated into the circuit and the current rise time is too short, even though there seems to be no issues (e.g. inrush current, etc.) with the waveform of the current when observed with an oscilloscope, it may cause the LDs to emit excessive light resulting in it being damaged.
- The forward voltage (V_F) and the optical output power vary depending on the operating temperature (T_B). Additionally, the optical output power will gradually decrease over time as the operating time increases.
- When the power supply is turned on or off, the circuit may have issues (e.g. chattering, current spikes, inrush current, etc.) resulting in the Absolute Maximum Rating Current being exceeded. The circuit must be designed to prevent this from occurring.
- The failure modes for this LD can be either a short circuit or an open circuit and this is very important to understand when designing the circuit. If the LDs become short-circuited during operation, the forward voltage (V_F) may fluctuate resulting in damage to the circuit. To ensure that there are no issues with the designed circuit when these failure modes occur in the LDs, perform a sufficient verification prior to use. This verification should be performed taking into consideration the conditions/environments in which the end-product containing these LDs will actually be used.
- Depending on the environments where the LDs are operated, dust/particles may be attracted by the light of the LDs (i.e. optical dust collection effect) and adhere to the surface of the glass window, resulting in an adverse effect on the optical characteristics.

(4) Handling Precautions

- This LD is hermetically sealed; ensure that excessive force is not applied to the glass window of the cap and/or the sealing glass at the base of the lead when handling the LDs. If the glass is damaged, the hermetic seal for the LD may fail causing reduction in the optical output power and/or change in the shape of the beam to be accelerated and eventually the LD not to illuminate. Note that if the LD is picked up by holding the sides of the package with a method other than using tweezers or if the LD is dropped, it may also break the hermetic seal for the LD.
- It is recommended that this LD is electrically connected to the chosen application using a socket.

(5) Shape of the Beam

- This LD emits elliptical-shaped parallel light through the glass window. Adjust the shape of the beam emitted from the LD with a lens that is suitable for the chosen application when using the LD.
- Ensure that the glass window of the cap is not damaged/contaminated when handling the LDs. Otherwise, this may reduce the optical output power and/or change the far field pattern (FFP).

(6) Electrostatic Discharges (ESD) and Electrical Surges

- This LD is sensitive to transient excessive voltages (e.g. ESD, lightning surge). If this excessive voltage occurs in the circuit, it may cause the LD to be damaged causing issues (e.g. the LD to become dimmer or not to illuminate). Ensure that when handling the LDs, necessary measures are taken to protect them from ESD.

(7) Thermal Management

- The temperature of the LDs while in operation may vary depending on the thermal resistance of the heatsink and other materials (e.g. thermal interface materials, etc.), the condition of the contact surface of the heatsink (e.g. holes/opening, cavities/recesses, foreign materials, etc.), and how the LDs are attached to the heatsink (e.g. with/without grease, etc.). Once the heatsink and other materials are selected, sufficient verification should be performed to ensure that adequate adhesion is achieved and that Absolute Maximum Operating Temperature (T_B) is not exceeded.
- When thermal grease is used, ensure that it does not adversely affect the electrical characteristics of the LD and that the volatile compounds from the grease do not have an effect on the optical characteristics.

(8) Miscellaneous

- This LD is intended to be used for household appliances and electronic devices (e.g. mobile communication devices); it is not designed or manufactured for use in applications that require safety critical functions (e.g. automobiles, trains, vessels, aircraft, spacecraft, submarine repeaters, nuclear reactor control systems, traffic control equipment, combustion equipment, life support systems, safety devices, etc.). If the LDs are planned to be used for these applications, unless otherwise detailed in the specification, Nichia will neither guarantee that the LD is fit for that purpose nor be responsible for any resulting property damage, injuries and/or loss of life/health. This LD does not comply with IATF 16949 and is not intended for automotive applications.
- When using this LD for the chosen application (e.g. equipment, devices, etc.), design for safety must be considered to ensure that any LD failure does not cause any injuries to the human body and/or damage to property.
- This LD can fail at a certain rate. The failure rate and/or failure mode of the LD can vary depending on several factors (e.g. circuit, environmental conditions, etc.).
- Without prior written permission from Nichia, the Customer will not reverse engineer, disassemble or otherwise attempt to extract knowledge/design information from the LD. In the case of any incident that appears not to conform to the foregoing specifications, the local Nichia sales representative should be notified to discuss instructions on how to proceed while ensuring that the LD in question is not disassembled.
- Both the Customer and Nichia will agree on the official specifications for the supplied LDs before any programs are officially launched. Without this agreement in writing (i.e. Customer Specific Specification), changes to the content of this specification may occur without notice (e.g. changes to the foregoing specifications and appearance, discontinuation of the LDs, etc.).
- All copyrights and other intellectual property rights in this specification in any form are reserved by Nichia or the right holders who have granted Nichia permission to use the content. Without prior written permission from Nichia, no part of this specification may be reproduced in any form or by any means.